

Light efficiency:



Output: 917 lm

Light quality:



Peak: 2471 cd

Power: 15.0 W



Beam angle

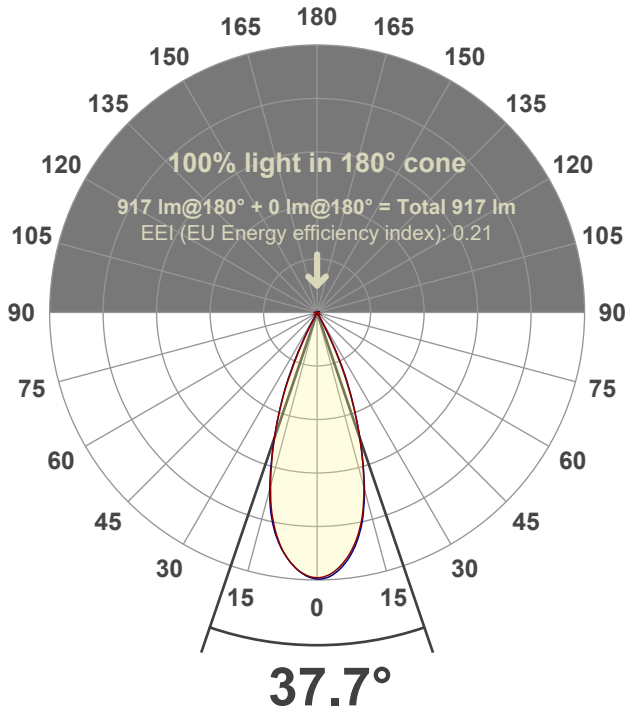

Test number:

GR-F-A14-2722-FL-SQ-Rev2

Luminaire Model:

Graffiti Regress Square Fixed Downlight-A14-2722 38° Optic

Date and time:

6/30/2022 6:06:37 PM

Delivered Lumens

917

Spectra

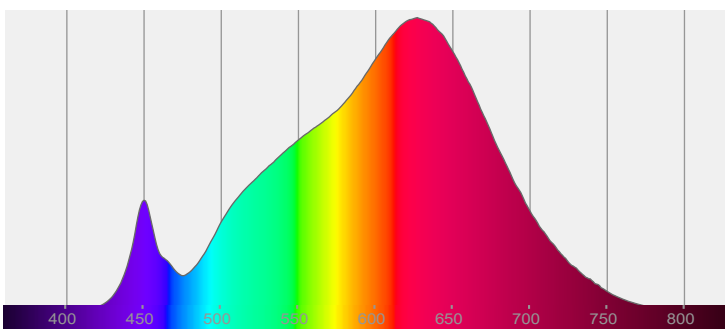

CRI: 93.5 (R1-R8)

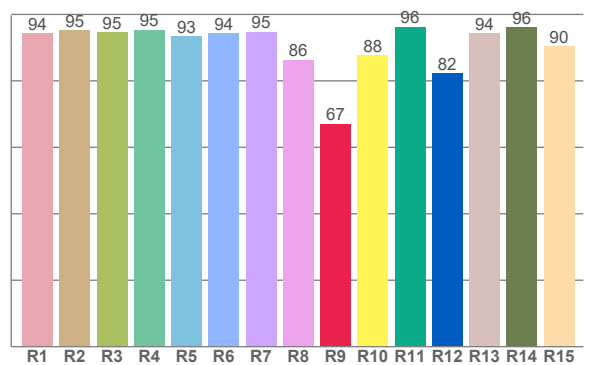

Color parameters

	Color rendering index	Red component	Color fidelity	Color gamut	Color quality scale	Color coordinate cie 1931	Color coordinate cie 1931	Color coordinate	Color coordinate	Color deviation from black body
	CRI	CRI R9	TM30 R _f	TM30 R _g	CQS	x	y	u	v	Δuv
	93.5	67.1	92.8	100.7	91.5	0.458	0.414	0.260	0.352	0.0014

R_f 92.8
Fidelity index R_f

R_g 100.7
Gammut index R_g

TM30: 92.8

TM-30Color

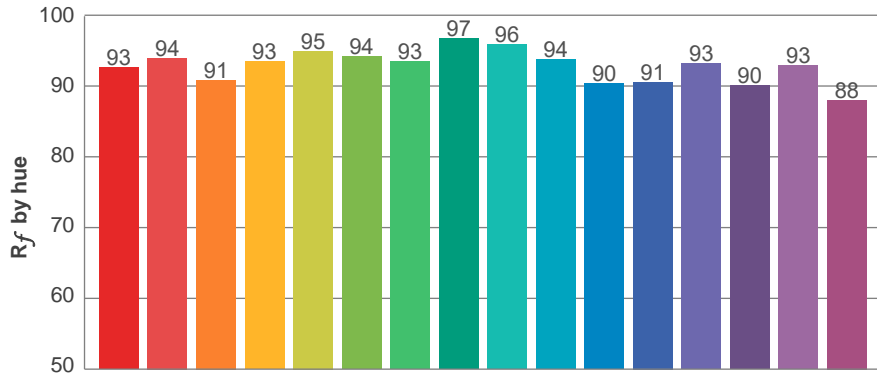

Hue Bin	R_f	Graphic shifts (%)	
		Chroma	Hue
1	93	-4%	-1%
2	94	-3%	2%
3	91	-1%	5%
4	93	0%	3%
5	95	2%	4%
6	94	4%	0%
7	93	1%	-4%
8	97	0%	-2%
9	96	-2%	-1%
10	94	-2%	3%
11	90	0%	7%
12	91	4%	2%
13	93	4%	-3%
14	90	5%	-6%
15	93	0%	-4%
16	88	-1%	-9%

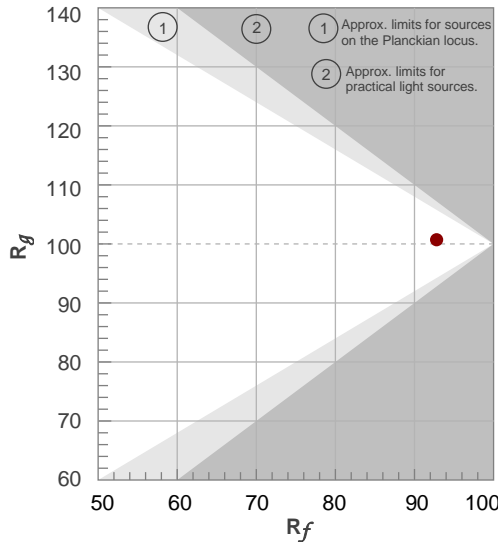

Color vector graphics

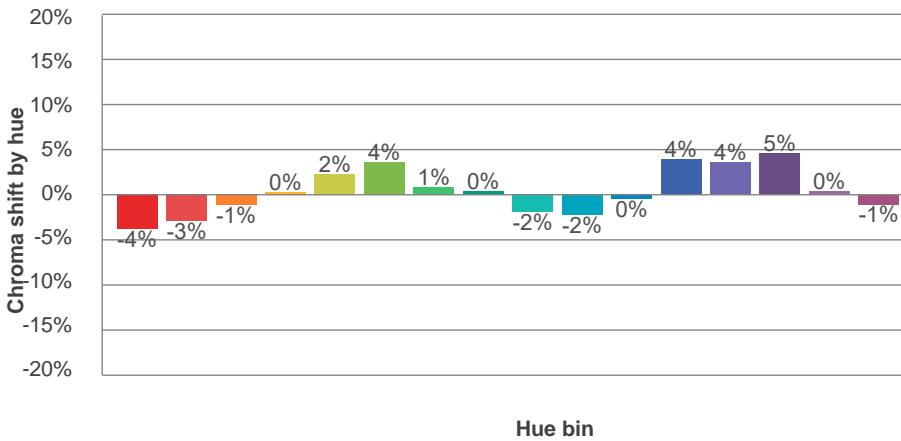
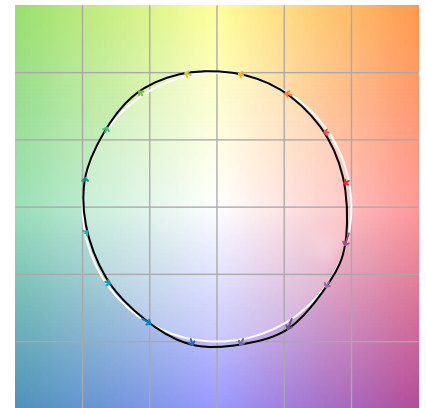

Color distortion

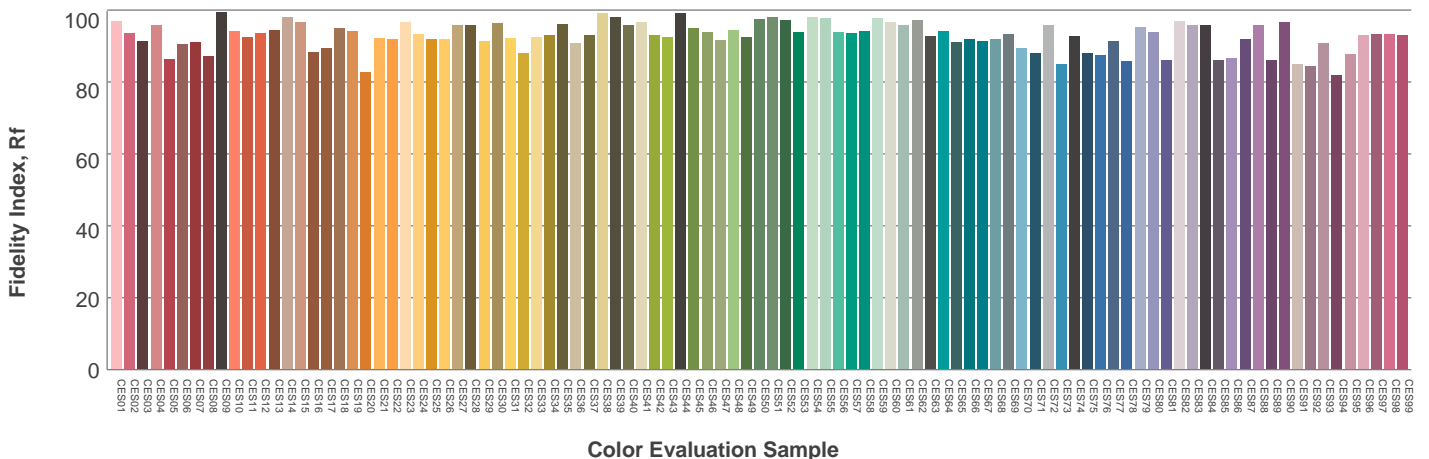

Beam details

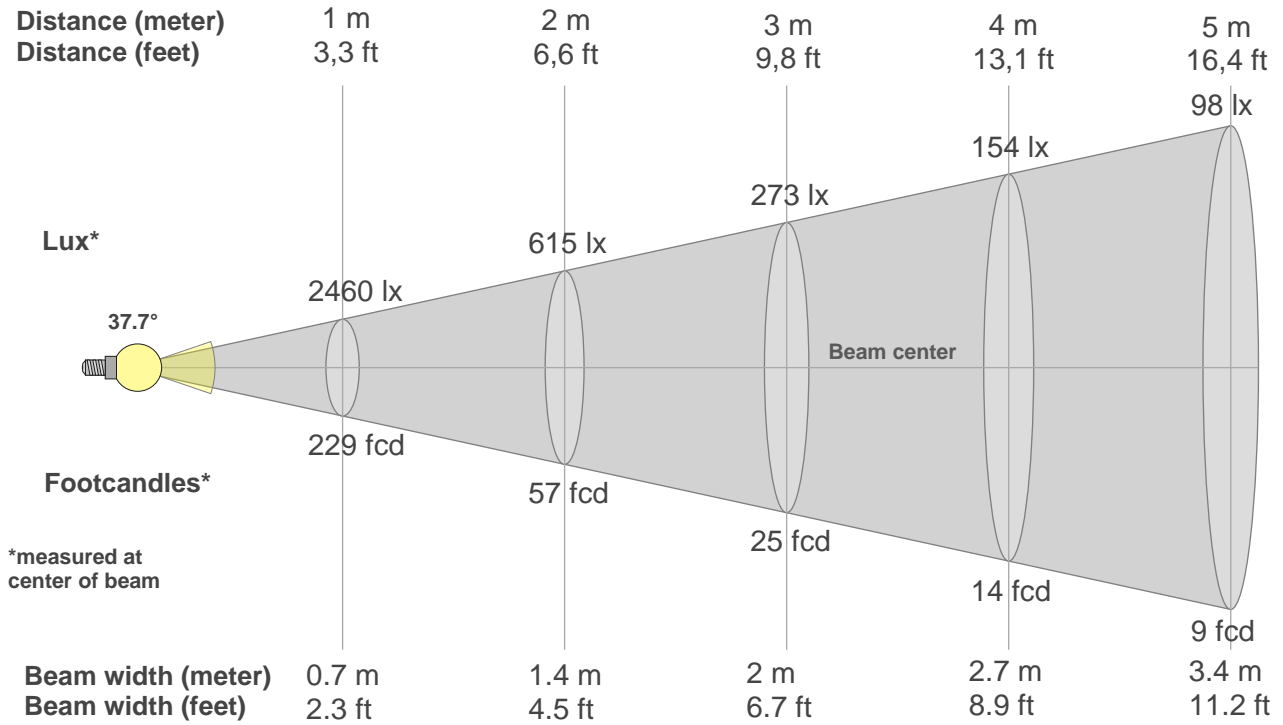

Beam intensities from 1-20m

1m	2m	3m	4m	5m	6m	7m	8m	9m	10m	11m	12m	13m	14m	15m	16m	17m	18m	19m	20m
3.3ft	6.6ft	9.8ft	13.1ft	16.4ft	19.7ft	23ft	26.2ft	29.5ft	32.8ft	36.1ft	39.4ft	42.7ft	45.9ft	49.2ft	52.5ft	55.8ft	59.1ft	62.3ft	65.6ft
2460lx	615lx	273lx	154lx	98lx	68lx	50lx	38lx	30lx	25lx	20lx	17lx	15lx	13lx	11lx	10lx	9lx	8lx	7lx	6lx
228.6fcd	57.1fcd	25.4fcd	14.3fcd	9.1fcd	6.3fcd	4.7fcd	3.6fcd	2.8fcd	2.3fcd	1.9fcd	1.6fcd	1.4fcd	1.2fcd	1fcd	0.9fcd	0.8fcd	0.7fcd	0.6fcd	0.6fcd

Intensities in 0° c-plane

0°	2°	4°	6°	8°	10°	12°	14°	16°	18°	20°	22°	24°	26°	28°	30°	32°	34°	36°	38°
2460	2439	2396	2329	2240	2124	1974	1786	1566	1331	1095	866	653	428	227	86	21	11	8	6
100%	99%	97%	95%	91%	86%	80%	73%	64%	54%	44%	35%	27%	17%	9%	4%	1%	0%	0%	0%

Intensities in 90° c-plane

0°	2°	4°	6°	8°	10°	12°	14°	16°	18°	20°	22°	24°	26°	28°	30°	32°	34°	36°	38°
2460	2456	2417	2351	2261	2146	1997	1804	1577	1335	1089	844	606	369	171	63	23	13	8	6
100%	100%	98%	96%	92%	87%	81%	73%	64%	54%	44%	34%	25%	15%	7%	3%	1%	1%	0%	0%

Intensities in 180° c-plane

0°	2°	4°	6°	8°	10°	12°	14°	16°	18°	20°	22°	24°	26°	28°	30°	32°	34°	36°	38°
2460	2440	2400	2331	2237	2115	1963	1778	1558	1328	1097	854	592	350	161	43	18	12	8	6
100%	99%	98%	95%	91%	86%	80%	72%	63%	54%	45%	35%	24%	14%	7%	2%	1%	0%	0%	0%

Intensities in 270° c-plane

0°	2°	4°	6°	8°	10°	12°	14°	16°	18°	20°	22°	24°	26°	28°	30°	32°	34°	36°	38°
2460	2449	2401	2330	2240	2127	1985	1807	1581	1335	1091	861	631	397	188	53	22	12	8	5
100%	100%	98%	95%	91%	86%	81%	73%	64%	54%	44%	35%	26%	16%	8%	2%	1%	0%	0%	0%

Beam angle 50%	Field angle 10%	Cutoff angle 2,5%	Intensity ratio in 120° cone	Intensity ratio in 90° cone
37.7°	54.7°	60°	99.3%	99.0%

LAMPS (number of lamps)
50

Light planning Luminaire budgetary diagram

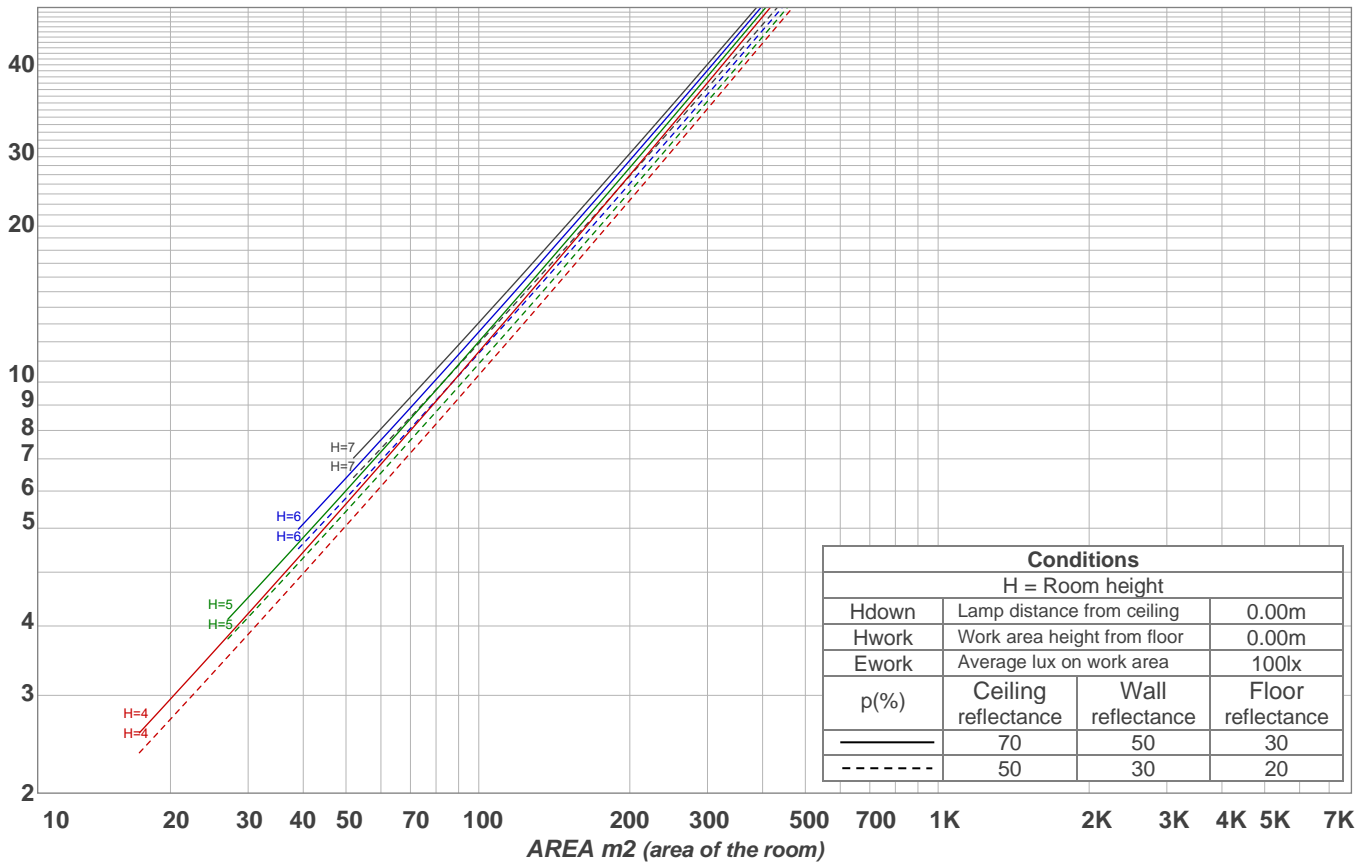

Luminaire budgetary diagram AREA m2 (area of the room) Coefficients of Utilization

Ceiling reflectance	80				70				50			30			10			0			
Wall reflectance	70	50	30	10	70	50	30	10	50	30	10	50	30	10	50	30	10	50	30	10	0
Floor reflectance	20	20	20	20	20	20	20	20	20	20	20	20	20	20	20	20	20	20	20	20	0
RCR	(RCR: Room Cavity Ratio) Room Values are expressed as percentage of Lumens delivered to the task surface																				
0	119	119	119	119	116	116	116	116	111	111	111	106	106	106	102	102	102	100	100	100	
1	115	112	110	108	112	110	108	107	106	105	103	103	101	100	99	98	98	96	96	96	
2	111	107	103	101	108	105	102	100	102	100	98	99	97	95	96	95	94	92	92	92	
3	107	102	98	95	105	100	97	94	98	95	93	96	93	91	93	91	90	88	88	88	
4	103	97	93	90	101	96	92	89	94	91	88	92	90	87	91	88	86	85	85	85	
5	100	93	89	86	98	92	88	85	91	87	85	89	86	84	88	85	83	82	82	82	
6	96	90	85	82	95	89	85	82	88	84	81	86	83	81	85	82	80	79	79	79	
7	93	86	82	79	92	86	81	78	85	81	78	84	80	78	83	80	77	76	76	76	
8	90	83	79	76	89	83	78	76	82	78	75	81	77	75	80	77	75	74	74	74	
9	88	80	76	73	87	80	76	73	79	75	73	78	75	72	78	74	72	71	71	71	
10	85	78	73	70	84	77	73	70	77	73	70	76	72	70	75	72	70	69	69	69	

Zonal Lumen Summary

0°-10°	10°-20°	20°-30°	30°-40°	40°-50°	50°-60°	60°-70°	70°-80°	80°-90°
219 lm	454 lm	226 lm	8.28 lm	2.29 lm	1.79 lm	1.92 lm	1.72 lm	2.25 lm
90°-100°	100°-110°	110°-120°	120°-130°	130°-140°	140°-150°	150°-160°	160°-170°	170°-180°
0.000 lm	0.000 lm	0.000 lm	0.000 lm	0.000 lm	0.000 lm	0.000 lm	0.000 lm	0.000 lm