

Light efficiency:



Output: 1740 lm

Light quality:



Peak: 4397 cd

Power: 20.8 W



Beam angle

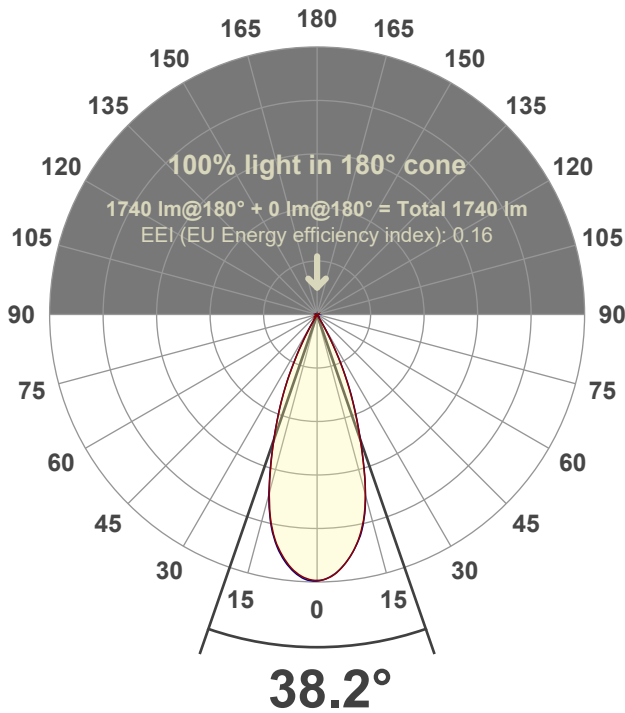

Test number:

**GR-F-CZ20-30k-FL-RD-Rev2**

Luminaire Model:

**Graffiti Regress Round Fixed Downlight-CZ20 30k 38° Optic**

Date and time:

**3/9/2022 4:13:25 PM**

Delivered Lumens

**1740**

Spectra

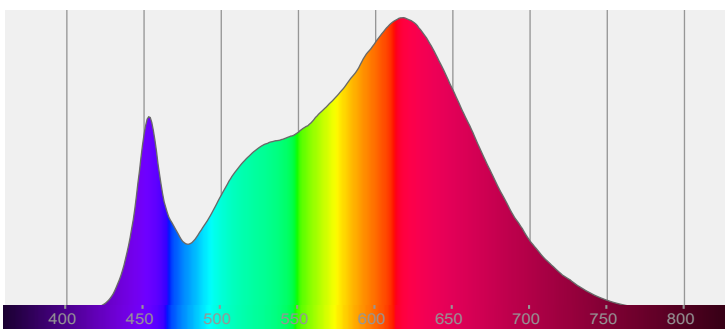

CRI: 94.4 (R1-R8)

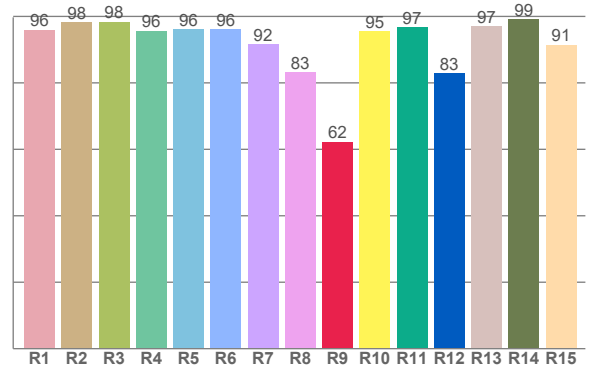

Color parameters

	Color rendering index	Red component	Color fidelity	Color gamut	Color quality scale	Color coordinate cie 1931	Color coordinate cie 1931	Color coordinate	Color coordinate	Color deviation from black body
	CRI	CRI R9	TM30 R <sub>f</sub>	TM30 R <sub>g</sub>	CQS	x	y	u	v	Δuv
	94.4	62.3	92.1	100.5	91.7	0.424	0.393	0.247	0.343	-0.0025

**$R_f$  92.1**  
Fidelity index  $R_f$

---

**$R_g$  100.5**  
Gammut index  $R_g$

TM30: 92.1

TM-30Color

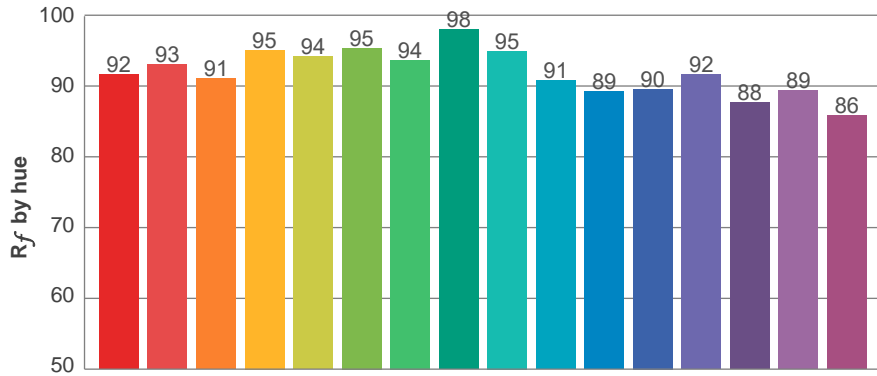

Hue Bin	$R_f$	Graphic shifts (%)	
		Chroma	Hue
1	92	-4%	0%
2	93	-3%	3%
3	91	0%	4%
4	95	0%	2%
5	94	-1%	2%
6	95	2%	0%
7	94	-1%	-1%
8	98	1%	0%
9	95	-1%	3%
10	91	-1%	5%
11	89	2%	7%
12	90	6%	0%
13	92	3%	-5%
14	88	4%	-9%
15	89	-1%	-6%
16	86	-1%	-11%

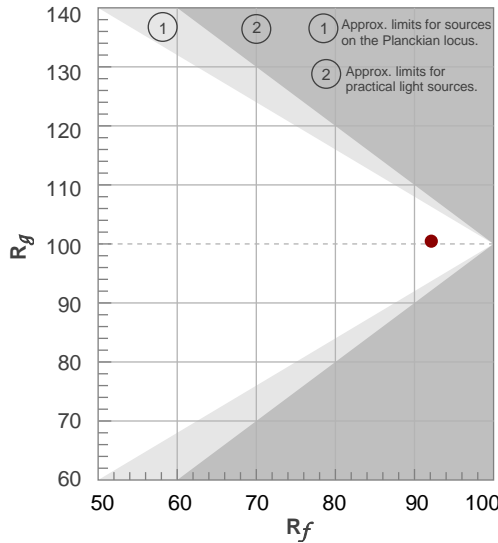

Color vector graphics

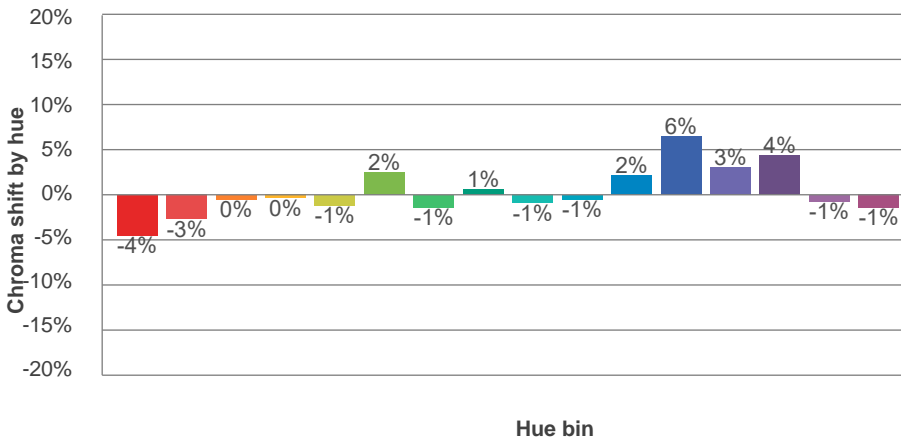
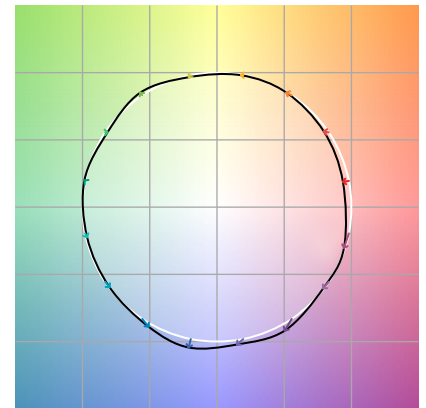

Color distortion

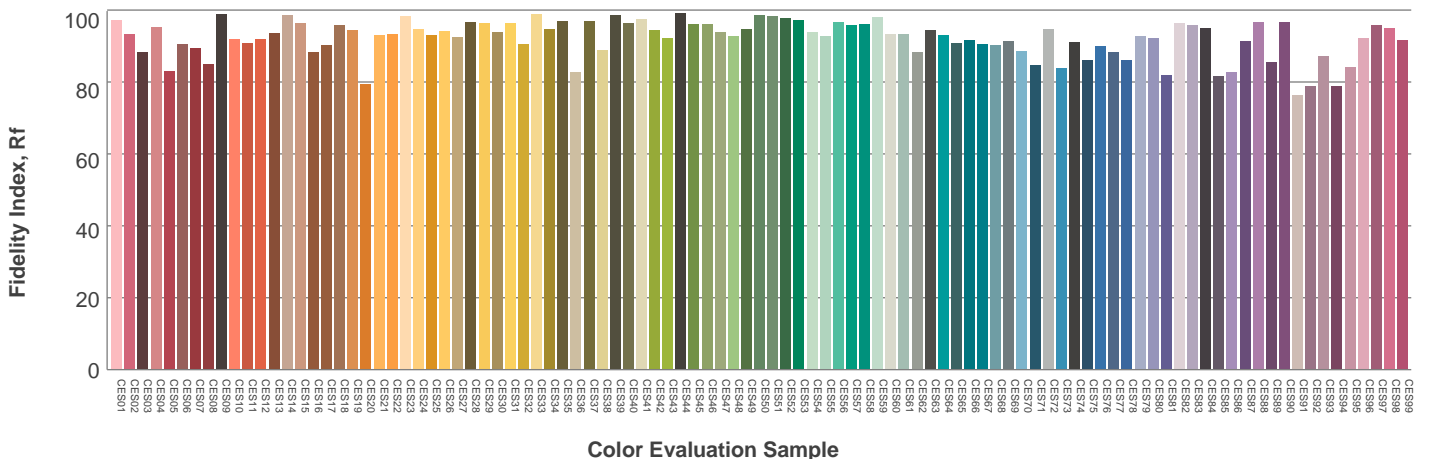

### Beam details

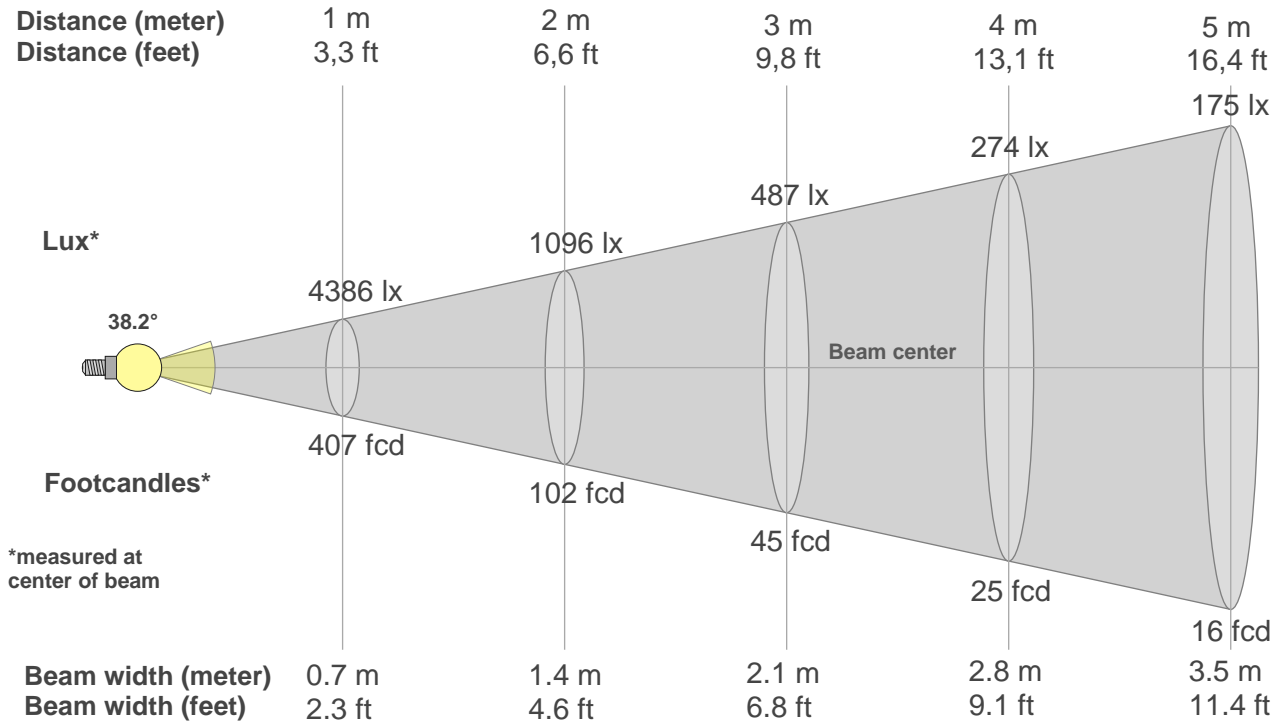

#### Beam intensities from 1-20m

1m	2m	3m	4m	5m	6m	7m	8m	9m	10m	11m	12m	13m	14m	15m	16m	17m	18m	19m	20m
3.3ft	6.6ft	9.8ft	13.1ft	16.4ft	19.7ft	23ft	26.2ft	29.5ft	32.8ft	36.1ft	39.4ft	42.7ft	45.9ft	49.2ft	52.5ft	55.8ft	59.1ft	62.3ft	65.6ft
4386lx	1096lx	487lx	274lx	175lx	122lx	90lx	69lx	54lx	44lx	36lx	30lx	26lx	22lx	19lx	17lx	15lx	14lx	12lx	11lx
407.4fcd	101.9fcd	45.3fcd	25.5fcd	16.3fcd	11.3fcd	8.3fcd	6.4fcd	5fcd	4.1fcd	3.4fcd	2.8fcd	2.4fcd	2.1fcd	1.8fcd	1.6fcd	1.4fcd	1.3fcd	1.1fcd	1fcd

#### Intensities in 0° c-plane

0°	2°	4°	6°	8°	10°	12°	14°	16°	18°	20°	22°	24°	26°	28°	30°	32°	34°	36°	38°
4386	4356	4286	4165	4008	3813	3568	3259	2875	2423	2002	1615	1247	892	556	269	92	27	12	10
100%	99%	98%	95%	91%	87%	81%	74%	66%	55%	46%	37%	28%	20%	13%	6%	2%	1%	0%	0%

#### Intensities in 90° c-plane

0°	2°	4°	6°	8°	10°	12°	14°	16°	18°	20°	22°	24°	26°	28°	30°	32°	34°	36°	38°
4386	4357	4277	4157	4005	3821	3595	3286	2876	2437	2018	1635	1273	899	555	275	96	19	9	8
100%	99%	98%	95%	91%	87%	82%	75%	66%	56%	46%	37%	29%	21%	13%	6%	2%	0%	0%	0%

#### Intensities in 180° c-plane

0°	2°	4°	6°	8°	10°	12°	14°	16°	18°	20°	22°	24°	26°	28°	30°	32°	34°	36°	38°
4386	4358	4295	4189	4032	3836	3576	3241	2842	2414	2008	1636	1264	888	533	240	67	22	10	7
100%	99%	98%	96%	92%	87%	82%	74%	65%	55%	46%	37%	29%	20%	12%	5%	2%	1%	0%	0%

#### Intensities in 270° c-plane

0°	2°	4°	6°	8°	10°	12°	14°	16°	18°	20°	22°	24°	26°	28°	30°	32°	34°	36°	38°
4386	4378	4313	4204	4055	3863	3607	3268	2859	2430	2016	1629	1258	883	548	275	90	17	10	8
100%	100%	98%	96%	92%	88%	82%	75%	65%	55%	46%	37%	29%	20%	13%	6%	2%	0%	0%	0%

Beam angle 50%	Field angle 10%	Cutoff angle 2,5%	Intensity ratio in 120° cone	Intensity ratio in 90° cone
38.2°	57.4°	63.3°	99.4%	99.1%

LAMPS (number of lamps)  
50

### Light planning Luminaire budgetary diagram

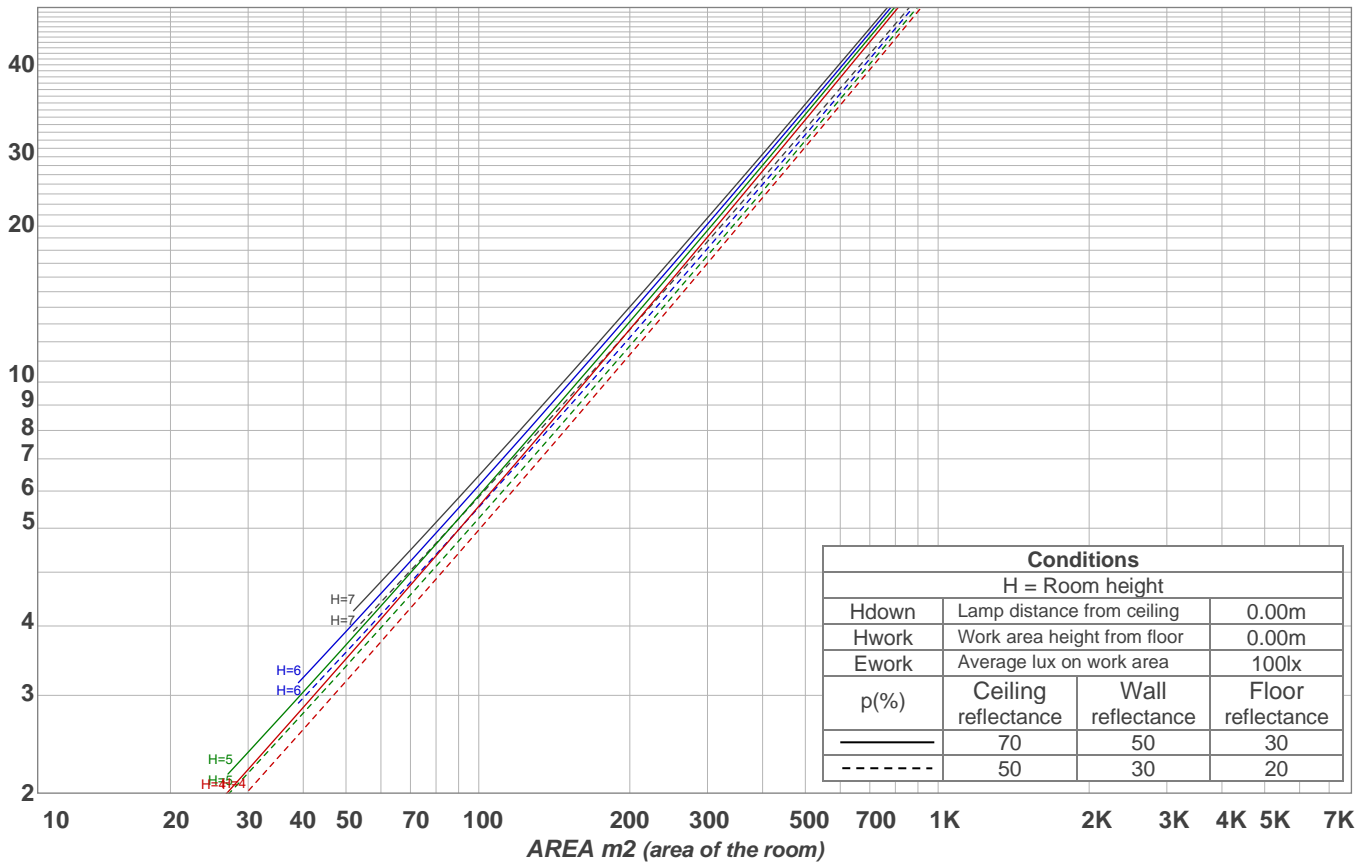

### Luminaire budgetary diagram AREA m2 (area of the room) Coefficients of Utilization

Ceiling reflectance	80				70				50			30			10			0
Wall reflectance	70	50	30	10	70	50	30	10	50	30	10	50	30	10	50	30	10	0
Floor reflectance	20	20	20	20	20	20	20	20	20	20	20	20	20	20	20	20	20	0
RCR	(RCR: Room Cavity Ratio)																	
	Room Values are expressed as percentage of Lumens delivered to the task surface																	
0	119	119	119	119	116	116	116	116	111	111	111	106	106	106	102	102	102	100
1	115	112	110	108	112	110	108	107	106	105	103	102	101	100	99	98	97	96
2	110	106	103	100	108	105	102	99	102	99	97	99	97	95	96	95	93	92
3	106	101	97	94	105	100	96	94	98	95	92	95	93	91	93	91	89	88
4	103	97	93	89	101	96	92	89	94	90	88	92	89	87	90	88	86	85
5	99	93	88	85	98	92	88	85	90	87	84	89	86	83	87	85	82	81
6	96	89	84	81	95	88	84	81	87	83	80	86	82	80	84	82	79	78
7	93	86	81	78	92	85	81	78	84	80	77	83	79	77	82	79	76	75
8	90	82	78	75	89	82	77	74	81	77	74	80	76	74	79	76	74	73
9	87	79	75	72	86	79	75	72	78	74	71	77	74	71	77	73	71	70
10	84	77	72	69	83	76	72	69	76	72	69	75	71	69	74	71	69	68

### Zonal Lumen Summary

0°-10°	10°-20°	20°-30°	30°-40°	40°-50°	50°-60°	60°-70°	70°-80°	80°-90°
392 lm	826 lm	478 lm	26.5 lm	3.74 lm	3.08 lm	3.21 lm	3.12 lm	4.24 lm
90°-100°	100°-110°	110°-120°	120°-130°	130°-140°	140°-150°	150°-160°	160°-170°	170°-180°
0.000 lm	0.000 lm	0.000 lm	0.000 lm	0.000 lm	0.000 lm	0.000 lm	0.000 lm	0.000 lm