

Light efficiency:



Output: 924 lm

Light quality:



Peak: 2180 cd

Power: 14.6 W

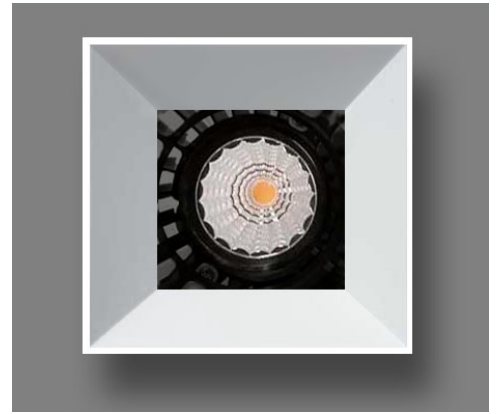

Beam angle

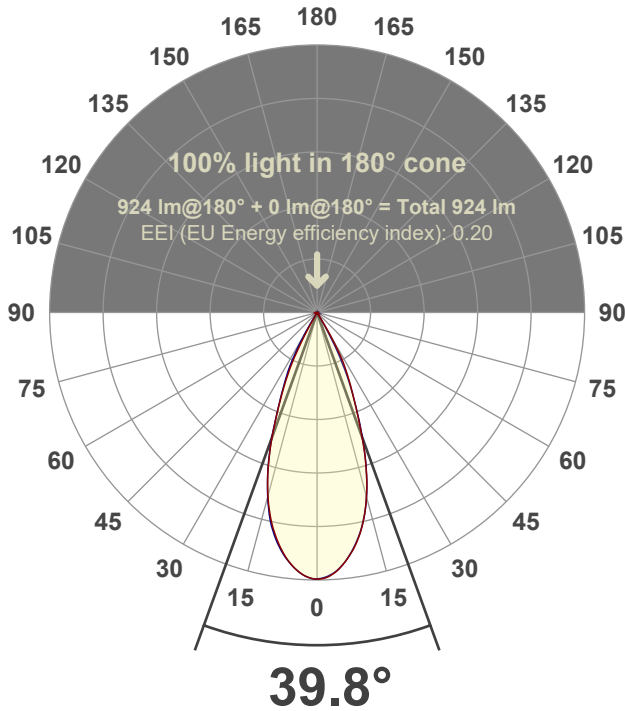

Test number:

GR-O-F-A14-3019-FL-SQ-Rev2

Luminaire Model:

Graffiti Open Square Fixed Downlight-A14-3019 38° Optic

Date and time:

6/30/2022 12:02:00 PM

Delivered Lumens

924

Spectra

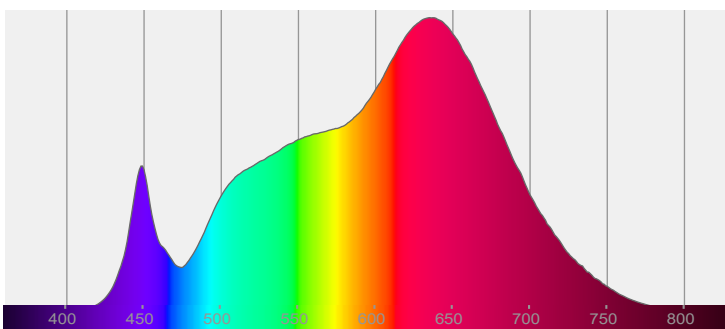

CRI: 96.2 (R1-R8)

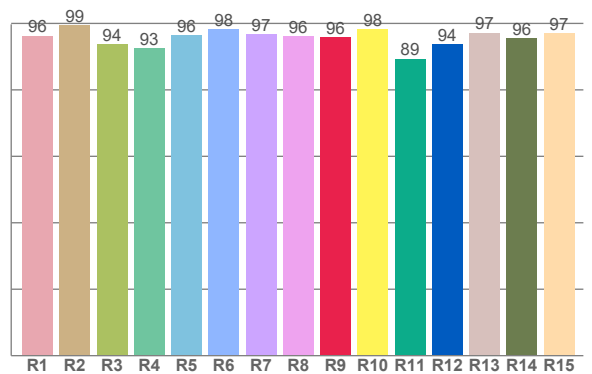

Color parameters

|  | Color rendering index | Red component | Color fidelity      | Color gamut         | Color quality scale | Color coordinate cie 1931 | Color coordinate cie 1931 | Color coordinate | Color coordinate | Color deviation from black body |
|--|-----------------------|---------------|---------------------|---------------------|---------------------|---------------------------|---------------------------|------------------|------------------|---------------------------------|
|  | CRI                   | CRI R9        | TM30 R <sub>f</sub> | TM30 R <sub>g</sub> | CQS                 | x                         | y                         | u                | v                | Δuv                             |
|  | 96.2                  | 95.8          | 95.3                | 104.3               | 94.9                | 0.435                     | 0.402                     | 0.251            | 0.347            | -0.0008                         |

**$R_f$  95.3**

Fidelity index  $R_f$

---

**$R_g$  104.3**

Gammut index  $R_g$

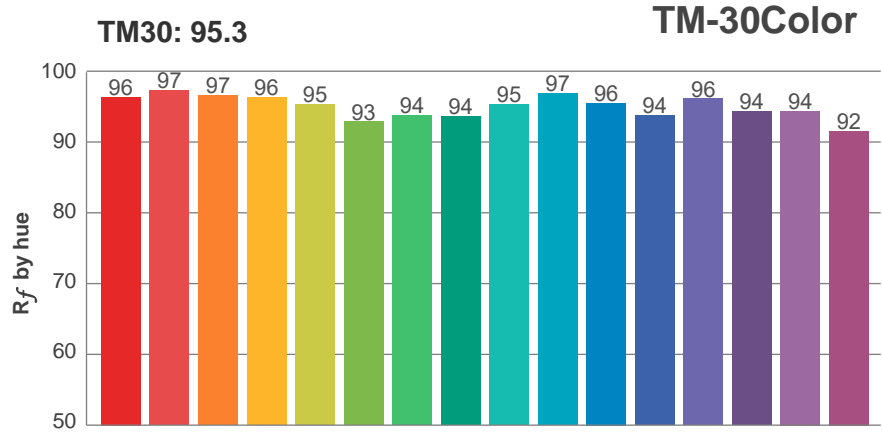

| Hue Bin | $R_f$ | Graphic shifts (%) |     |
|---------|-------|--------------------|-----|
|         |       | Chroma             | Hue |
| 1       | 96    | 1%                 | -2% |
| 2       | 97    | 1%                 | -1% |
| 3       | 97    | 1%                 | 1%  |
| 4       | 96    | 1%                 | 1%  |
| 5       | 95    | 1%                 | 2%  |
| 6       | 93    | 5%                 | 1%  |
| 7       | 94    | 4%                 | -1% |
| 8       | 94    | 3%                 | -2% |
| 9       | 95    | 1%                 | -2% |
| 10      | 97    | 0%                 | -1% |
| 11      | 96    | 0%                 | 2%  |
| 12      | 94    | 3%                 | 1%  |
| 13      | 96    | 3%                 | -1% |
| 14      | 94    | 4%                 | -1% |
| 15      | 94    | 3%                 | -2% |
| 16      | 92    | 4%                 | -6% |

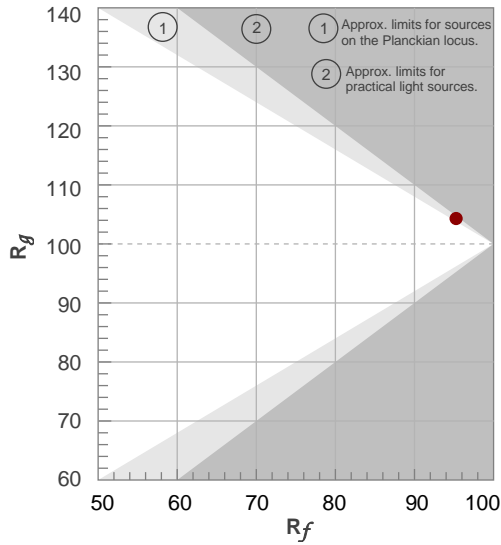

Color vector graphics

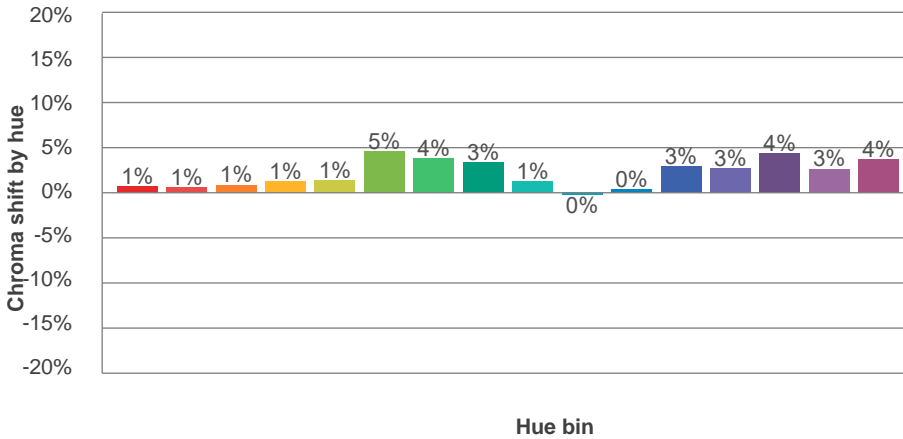
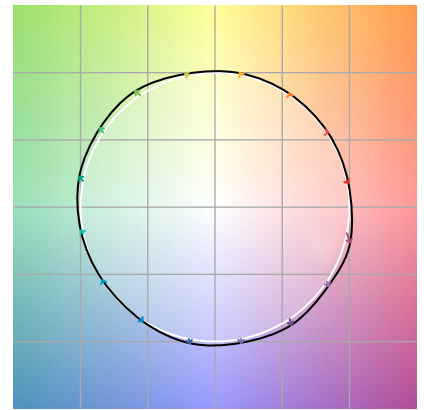

Color distortion

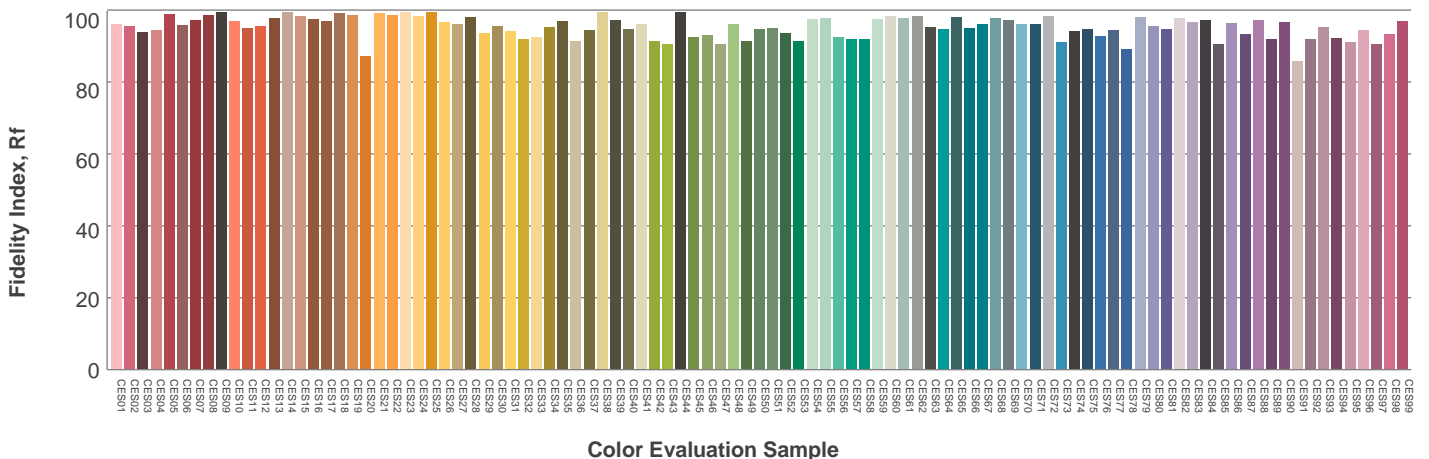

### Beam details

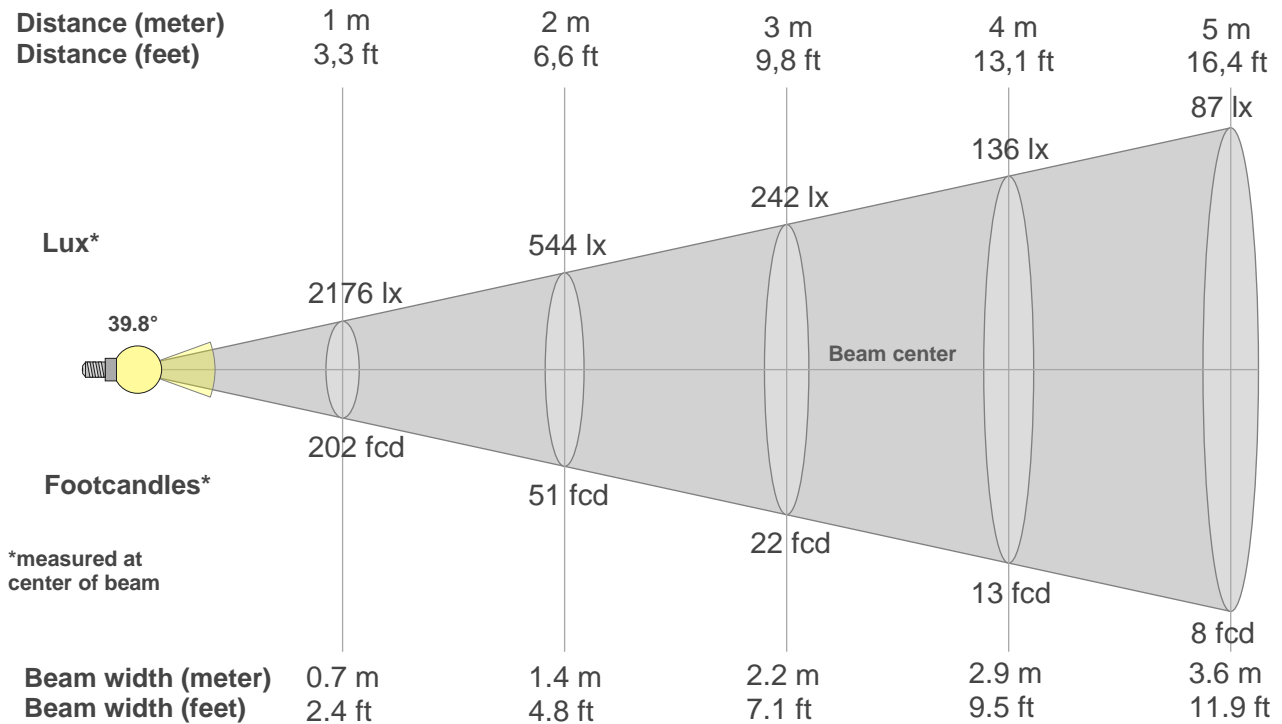

#### Beam intensities from 1-20m

| 1m       | 2m      | 3m      | 4m      | 5m     | 6m     | 7m     | 8m     | 9m     | 10m    | 11m    | 12m    | 13m    | 14m    | 15m    | 16m    | 17m    | 18m    | 19m    | 20m    |
|----------|---------|---------|---------|--------|--------|--------|--------|--------|--------|--------|--------|--------|--------|--------|--------|--------|--------|--------|--------|
| 3.3ft    | 6.6ft   | 9.8ft   | 13.1ft  | 16.4ft | 19.7ft | 23ft   | 26.2ft | 29.5ft | 32.8ft | 36.1ft | 39.4ft | 42.7ft | 45.9ft | 49.2ft | 52.5ft | 55.8ft | 59.1ft | 62.3ft | 65.6ft |
| 2176lx   | 544lx   | 242lx   | 136lx   | 87lx   | 60lx   | 44lx   | 34lx   | 27lx   | 22lx   | 18lx   | 15lx   | 13lx   | 11lx   | 10lx   | 9lx    | 8lx    | 7lx    | 6lx    | 5lx    |
| 202.2fcd | 50.5fcd | 22.5fcd | 12.6fcd | 8.1fcd | 5.6fcd | 4.1fcd | 3.2fcd | 2.5fcd | 2fcd   | 1.7fcd | 1.4fcd | 1.2fcd | 1fcd   | 0.9fcd | 0.8fcd | 0.7fcd | 0.6fcd | 0.6fcd | 0.5fcd |

#### Intensities in 0° c-plane

| 0°   | 2°   | 4°   | 6°   | 8°   | 10°  | 12°  | 14°  | 16°  | 18°  | 20°  | 22° | 24° | 26° | 28° | 30° | 32° | 34° | 36° | 38° |
|------|------|------|------|------|------|------|------|------|------|------|-----|-----|-----|-----|-----|-----|-----|-----|-----|
| 2176 | 2168 | 2127 | 2064 | 1987 | 1893 | 1779 | 1642 | 1477 | 1287 | 1078 | 876 | 708 | 571 | 441 | 268 | 113 | 25  | 7   | 5   |
| 100% | 100% | 98%  | 95%  | 91%  | 87%  | 82%  | 75%  | 68%  | 59%  | 50%  | 40% | 33% | 26% | 20% | 12% | 5%  | 1%  | 0%  | 0%  |

#### Intensities in 90° c-plane

| 0°   | 2°   | 4°   | 6°   | 8°   | 10°  | 12°  | 14°  | 16°  | 18°  | 20°  | 22° | 24° | 26° | 28° | 30° | 32° | 34° | 36° | 38° |
|------|------|------|------|------|------|------|------|------|------|------|-----|-----|-----|-----|-----|-----|-----|-----|-----|
| 2176 | 2160 | 2126 | 2064 | 1983 | 1887 | 1774 | 1639 | 1479 | 1290 | 1084 | 883 | 697 | 522 | 338 | 160 | 51  | 13  | 7   | 5   |
| 100% | 99%  | 98%  | 95%  | 91%  | 87%  | 81%  | 75%  | 68%  | 59%  | 50%  | 41% | 32% | 24% | 16% | 7%  | 2%  | 1%  | 0%  | 0%  |

#### Intensities in 180° c-plane

| 0°   | 2°   | 4°   | 6°   | 8°   | 10°  | 12°  | 14°  | 16°  | 18°  | 20°  | 22° | 24° | 26° | 28° | 30° | 32° | 34° | 36° | 38° |
|------|------|------|------|------|------|------|------|------|------|------|-----|-----|-----|-----|-----|-----|-----|-----|-----|
| 2176 | 2162 | 2123 | 2063 | 1984 | 1887 | 1771 | 1631 | 1469 | 1283 | 1077 | 862 | 679 | 507 | 314 | 143 | 36  | 12  | 8   | 6   |
| 100% | 99%  | 98%  | 95%  | 91%  | 87%  | 81%  | 75%  | 68%  | 59%  | 50%  | 40% | 31% | 23% | 14% | 7%  | 2%  | 1%  | 0%  | 0%  |

#### Intensities in 270° c-plane

| 0°   | 2°   | 4°   | 6°   | 8°   | 10°  | 12°  | 14°  | 16°  | 18°  | 20°  | 22° | 24° | 26° | 28° | 30° | 32° | 34° | 36° | 38° |
|------|------|------|------|------|------|------|------|------|------|------|-----|-----|-----|-----|-----|-----|-----|-----|-----|
| 2176 | 2161 | 2124 | 2066 | 1994 | 1900 | 1786 | 1642 | 1474 | 1287 | 1084 | 871 | 704 | 562 | 413 | 246 | 89  | 22  | 9   | 6   |
| 100% | 99%  | 98%  | 95%  | 92%  | 87%  | 82%  | 75%  | 68%  | 59%  | 50%  | 40% | 32% | 26% | 19% | 11% | 4%  | 1%  | 0%  | 0%  |

| Beam angle 50% | Field angle 10% | Cutoff angle 2,5% | Intensity ratio in 120° cone | Intensity ratio in 90° cone |
|----------------|-----------------|-------------------|------------------------------|-----------------------------|
| <b>39.8°</b>   | <b>59.6°</b>    | <b>64.5°</b>      | <b>99.3%</b>                 | <b>99.1%</b>                |

LAMPS (number of lamps)  
50

### Light planning Luminaire budgetary diagram

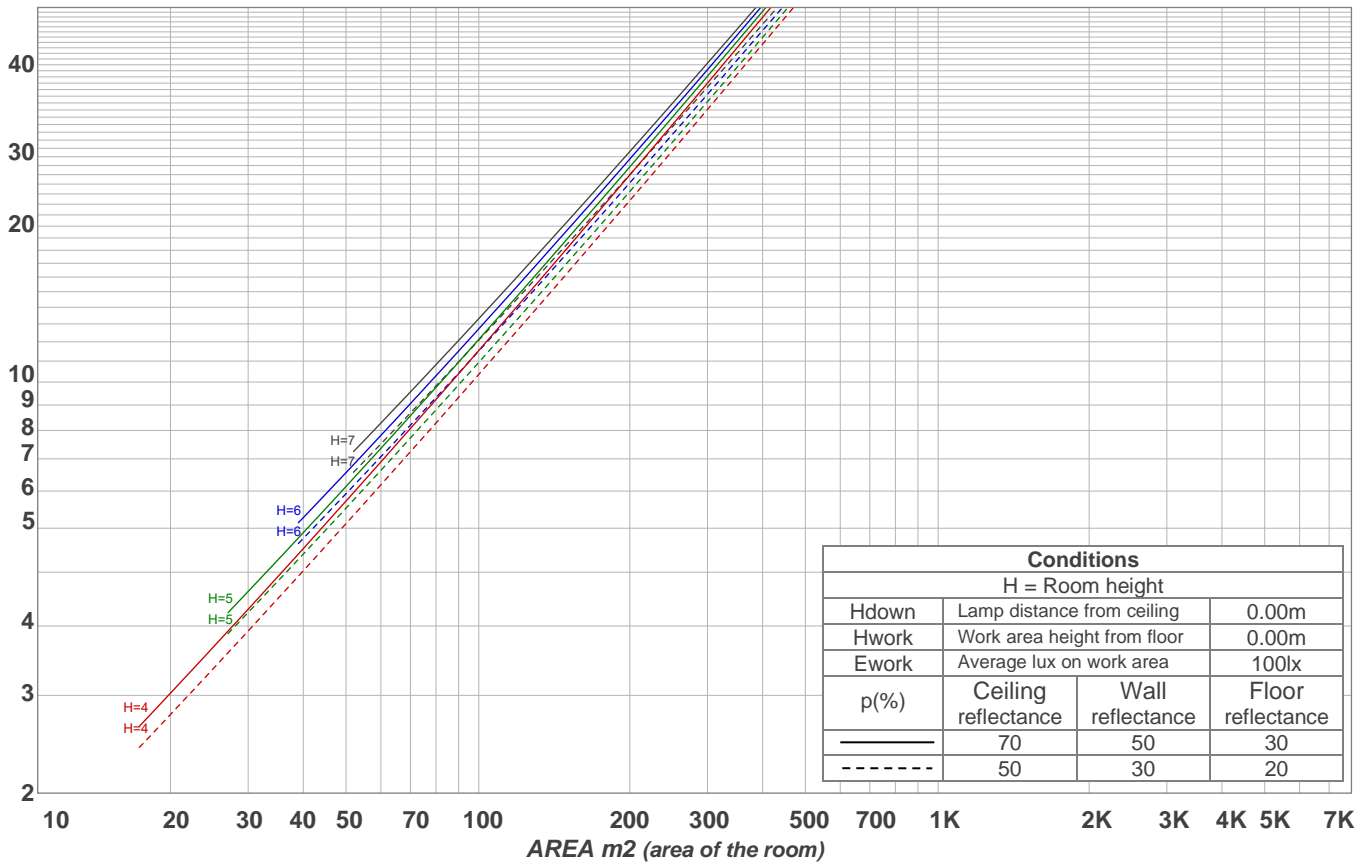

### Luminaire budgetary diagram AREA m2 (area of the room) Coefficients of Utilization

| Ceiling reflectance | 80  |     |     |     | 70  |     |     |     | 50  |     |     | 30  |     |     | 10  |     |     | 0   |     |     |     |
|---------------------|---|-----|-----|-----|-----|-----|-----|-----|-----|-----|-----|-----|-----|-----|-----|-----|-----|-----|-----|-----|-----|
| Wall reflectance    | 70  | 50  | 30  | 10  | 70  | 50  | 30  | 10  | 50  | 30  | 10  | 50  | 30  | 10  | 50  | 30  | 10  | 50  | 30  | 10  | 0   |
| Floor reflectance   | 20  | 20  | 20  | 20  | 20  | 20  | 20  | 20  | 20  | 20  | 20  | 20  | 20  | 20  | 20  | 20  | 20  | 20  | 20  | 20  | 0   |
| RCR                 | (RCR: Room Cavity Ratio)  |     |     |     |     |     |     |     |     |     |     |     |     |     |     |     |     |     |     |     |     |
|                     | Room Values are expressed as percentage of Lumens delivered to the task surface |     |     |     |     |     |     |     |     |     |     |     |     |     |     |     |     |     |     |     |     |
| 0                   | 119   | 119 | 119 | 119 | 116 | 116 | 116 | 116 | 111 | 111 | 111 | 106 | 106 | 106 | 102 | 102 | 102 | 100 | 100 | 100 | 100 |
| 1                   | 114   | 112 | 110 | 108 | 112 | 110 | 108 | 106 | 106 | 105 | 103 | 102 | 101 | 100 | 99  | 98  | 97  | 95  | 95  | 95  | 95  |
| 2                   | 110   | 106 | 103 | 100 | 108 | 105 | 102 | 99  | 101 | 99  | 97  | 98  | 97  | 95  | 96  | 94  | 93  | 91  | 91  | 91  | 91  |
| 3                   | 106   | 101 | 97  | 94  | 104 | 100 | 96  | 93  | 97  | 94  | 92  | 95  | 92  | 90  | 93  | 91  | 89  | 87  | 87  | 87  | 87  |
| 4                   | 102   | 96  | 92  | 89  | 101 | 95  | 91  | 88  | 93  | 90  | 87  | 91  | 88  | 86  | 90  | 87  | 85  | 84  | 84  | 84  | 84  |
| 5                   | 99  | 92  | 87  | 84  | 97  | 91  | 87  | 84  | 90  | 86  | 83  | 88  | 85  | 82  | 87  | 84  | 82  | 81  | 81  | 81  | 81  |
| 6                   | 95  | 88  | 83  | 80  | 94  | 87  | 83  | 80  | 86  | 82  | 79  | 85  | 81  | 79  | 84  | 81  | 78  | 77  | 77  | 77  | 77  |
| 7                   | 92  | 85  | 80  | 77  | 91  | 84  | 80  | 76  | 83  | 79  | 76  | 82  | 78  | 76  | 81  | 78  | 75  | 74  | 74  | 74  | 74  |
| 8                   | 89  | 81  | 77  | 73  | 88  | 81  | 76  | 73  | 80  | 76  | 73  | 79  | 75  | 73  | 78  | 75  | 72  | 71  | 71  | 71  | 71  |
| 9                   | 86  | 78  | 74  | 70  | 85  | 78  | 73  | 70  | 77  | 73  | 70  | 76  | 73  | 70  | 75  | 72  | 70  | 69  | 69  | 69  | 69  |
| 10                  | 83  | 75  | 71  | 68  | 82  | 75  | 71  | 68  | 74  | 70  | 68  | 74  | 70  | 67  | 73  | 70  | 67  | 66  | 66  | 66  | 66  |

### Zonal Lumen Summary

|          |           |           |           |           |           |           |           |           |
|----------|-----------|-----------|-----------|-----------|-----------|-----------|-----------|-----------|
| 0°-10°   | 10°-20°   | 20°-30°   | 30°-40°   | 40°-50°   | 50°-60°   | 60°-70°   | 70°-80°   | 80°-90°   |
| 194 lm   | 423 lm    | 277 lm    | 21.2 lm   | 1.99 lm   | 1.73 lm   | 1.84 lm   | 2.10 lm   | 2.13 lm   |
| 90°-100° | 100°-110° | 110°-120° | 120°-130° | 130°-140° | 140°-150° | 150°-160° | 160°-170° | 170°-180° |
| 0.000 lm | 0.000 lm  | 0.000 lm  | 0.000 lm  | 0.000 lm  | 0.000 lm  | 0.000 lm  | 0.000 lm  | 0.000 lm  |