

Light efficiency:



Output: 907 lm

Light quality:



Peak: 6172 cd

Power: 14.6 W

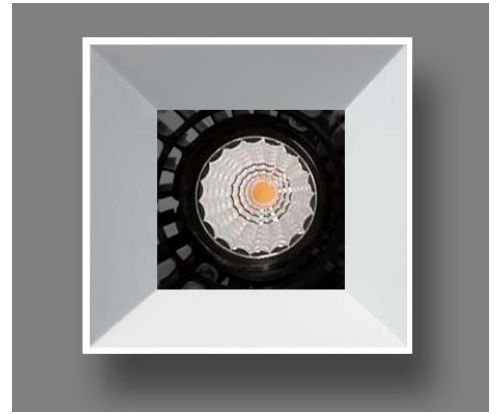

Beam angle

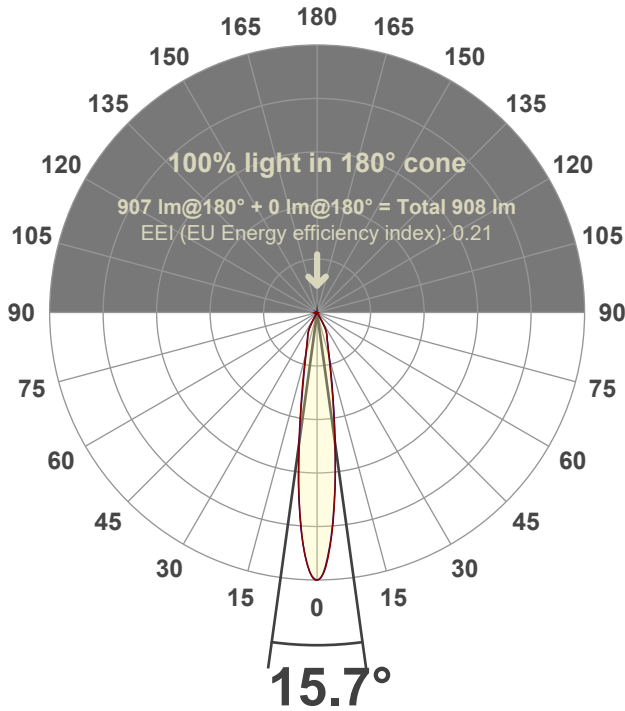

Test number:

GR-O-F-A14-3019-SP-SQ-Rev2

Luminaire Model:

Graffiti Open Square Fixed Downlight-A14-3019 15° Optic

Date and time:

6/30/2022 1:10:45 PM

Delivered Lumens

907

Spectra

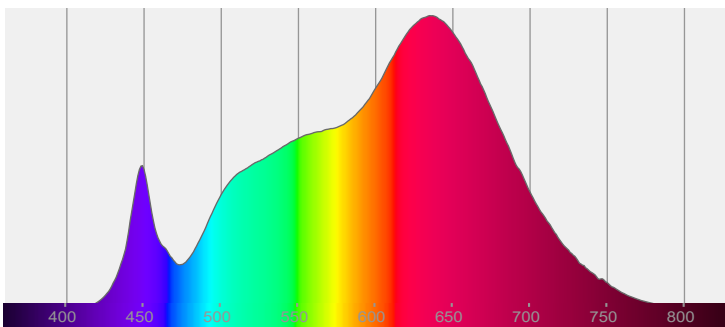

CRI: 96.2 (R1-R8)

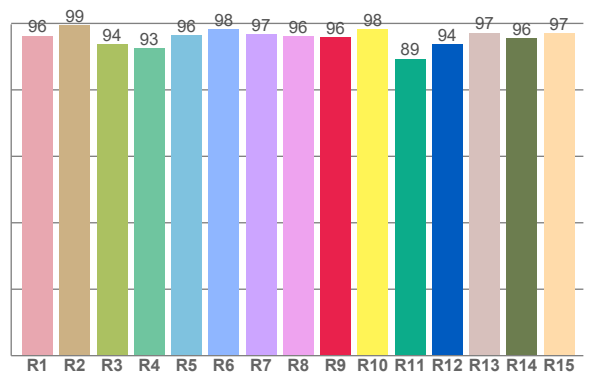

Color parameters

	Color rendering index	Red component	Color fidelity	Color gamut	Color quality scale	Color coordinate cie 1931	Color coordinate cie 1931	Color coordinate	Color coordinate	Color deviation from black body
	CRI	CRI R9	TM30 R _f	TM30 R _g	CQS	x	y	u	v	Δuv
	96.2	95.8	95.3	104.3	94.9	0.436	0.402	0.251	0.347	-0.0008

R_f 95.3

Fidelity index R_f

R_g 104.3

Gammut index R_g

TM30: 95.3

TM-30Color

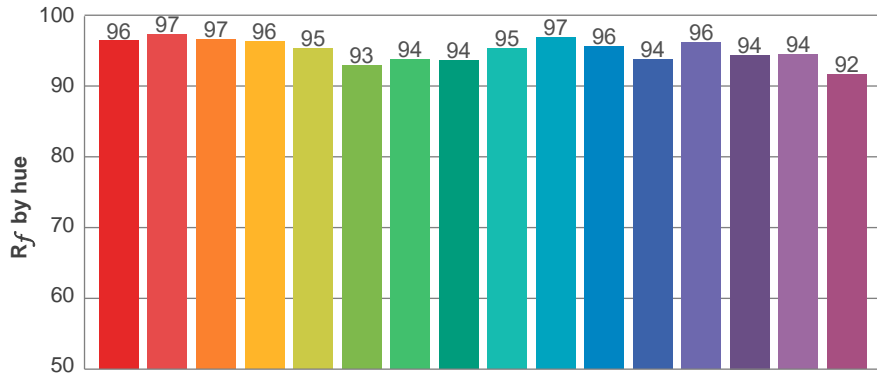

Hue Bin	R_f	Graphic shifts (%)	
		Chroma	Hue
1	96	1%	-1%
2	97	1%	-1%
3	97	1%	1%
4	96	1%	1%
5	95	1%	2%
6	93	5%	1%
7	94	4%	-1%
8	94	3%	-2%
9	95	1%	-2%
10	97	0%	-1%
11	96	0%	2%
12	94	3%	1%
13	96	3%	-1%
14	94	4%	-1%
15	94	3%	-2%
16	92	4%	-6%

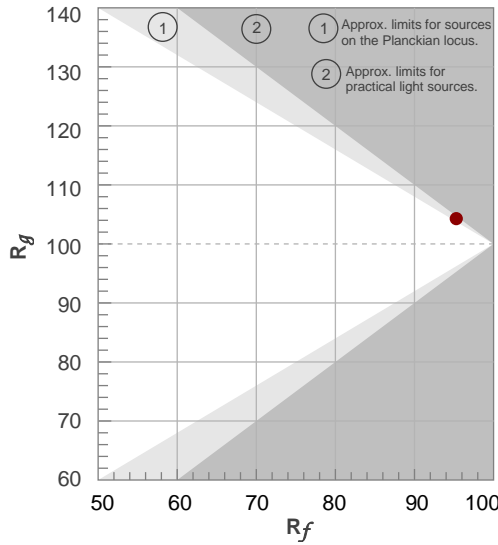

Color vector graphics

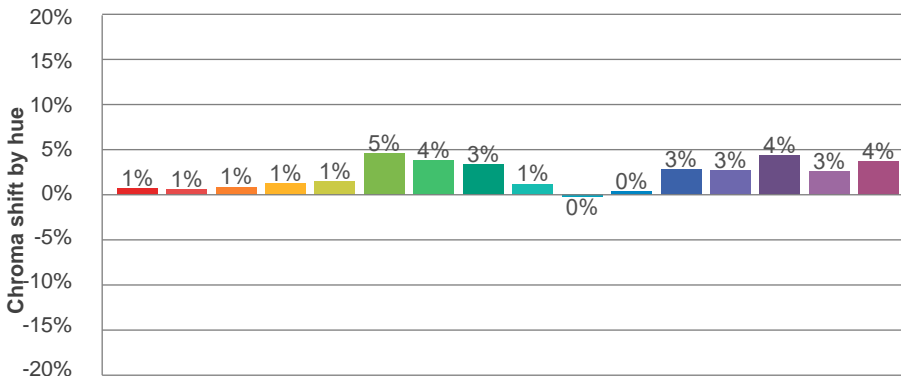
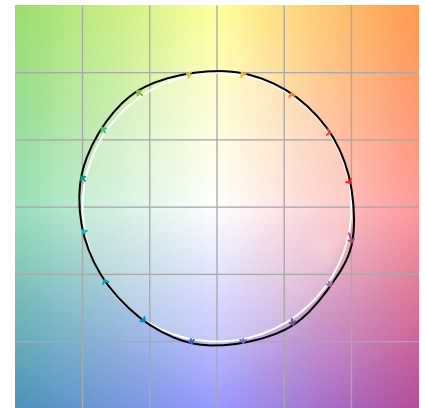

Color distortion

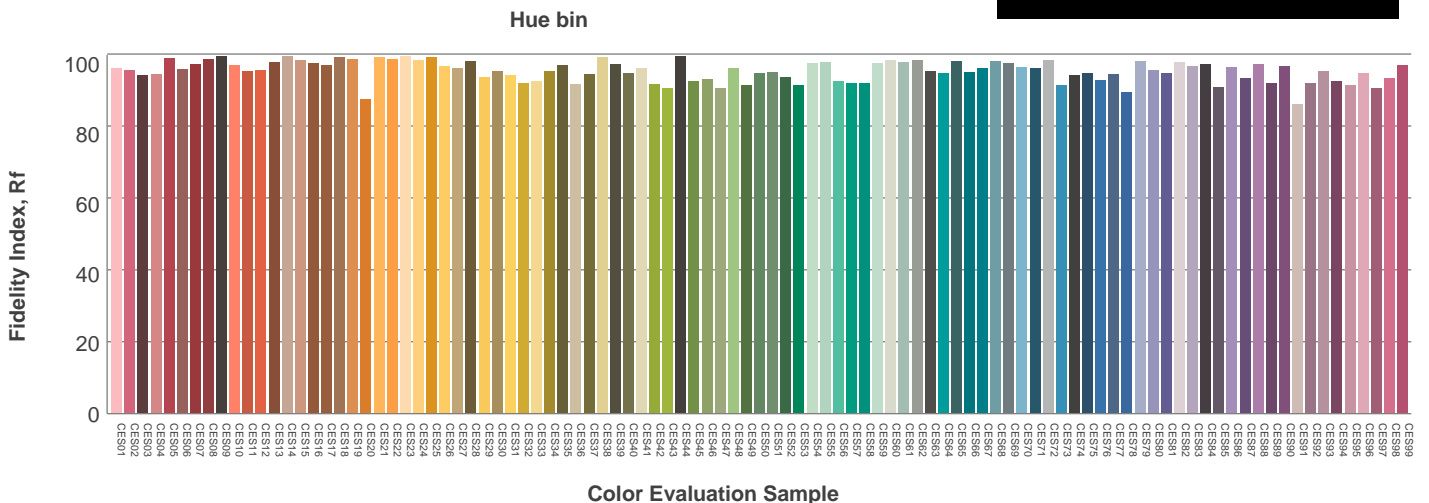

Beam details

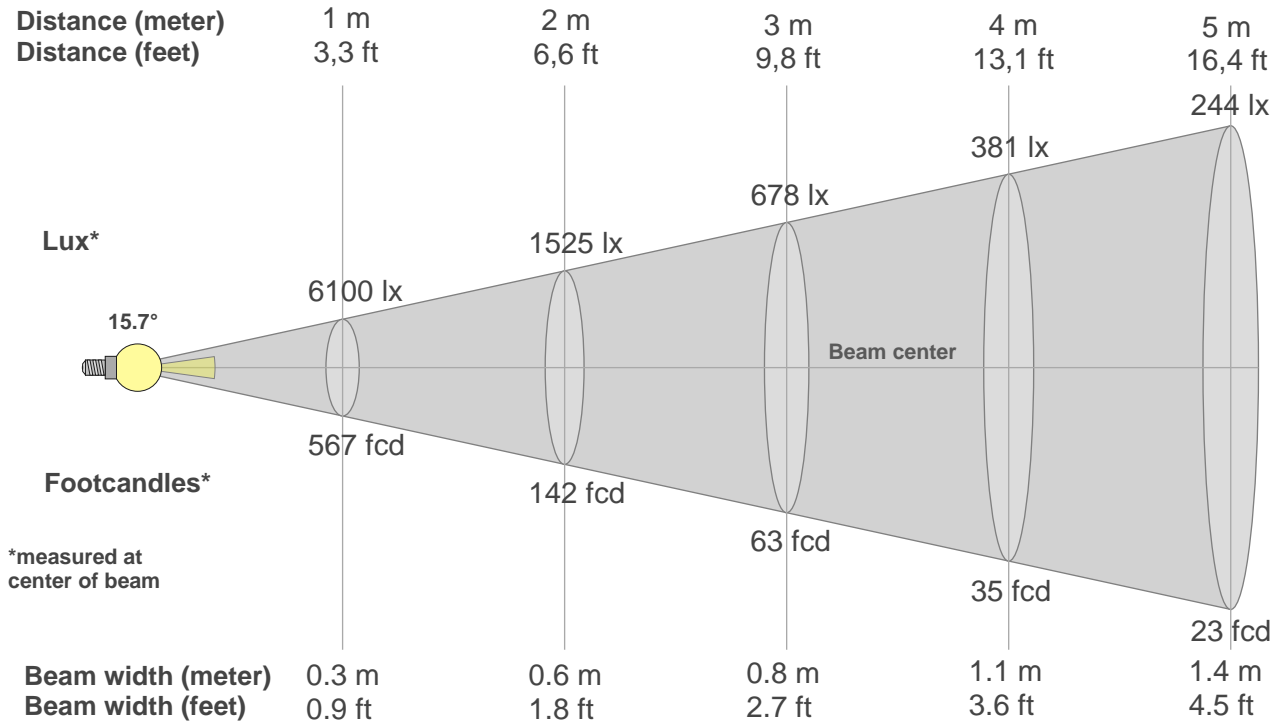

Beam intensities from 1-20m

1m	2m	3m	4m	5m	6m	7m	8m	9m	10m	11m	12m	13m	14m	15m	16m	17m	18m	19m	20m
3.3ft	6.6ft	9.8ft	13.1ft	16.4ft	19.7ft	23ft	26.2ft	29.5ft	32.8ft	36.1ft	39.4ft	42.7ft	45.9ft	49.2ft	52.5ft	55.8ft	59.1ft	62.3ft	65.6ft
6100lx	1525lx	678lx	381lx	244lx	169lx	124lx	95lx	75lx	61lx	50lx	42lx	36lx	31lx	27lx	24lx	21lx	19lx	17lx	15lx
566.7fc	141.7fc	63fcd	35.4fcd	22.7fcd	15.7fcd	11.6fcd	8.9fcd	7fcd	5.7fcd	4.7fcd	3.9fcd	3.4fcd	2.9fcd	2.5fcd	2.2fcd	2fcd	1.7fcd	1.6fcd	1.4fcd

Intensities in 0° c-plane

0°	2°	4°	6°	8°	10°	12°	14°	16°	18°	20°	22°	24°	26°	28°	30°	32°	34°	36°	38°
6100	5848	5040	4002	3000	2186	1607	1220	974	814	699	615	547	479	366	209	81	17	7	6
100%	96%	83%	66%	49%	36%	26%	20%	16%	13%	11%	10%	9%	8%	6%	3%	1%	0%	0%	0%

Intensities in 90° c-plane

0°	2°	4°	6°	8°	10°	12°	14°	16°	18°	20°	22°	24°	26°	28°	30°	32°	34°	36°	38°
6100	5762	4983	3993	3000	2234	1673	1278	1006	824	703	617	549	475	370	210	77	24	9	6
100%	94%	82%	65%	49%	37%	27%	21%	16%	14%	12%	10%	9%	8%	6%	3%	1%	0%	0%	0%

Intensities in 180° c-plane

0°	2°	4°	6°	8°	10°	12°	14°	16°	18°	20°	22°	24°	26°	28°	30°	32°	34°	36°	38°
6100	5826	5092	4080	3000	2164	1592	1202	944	776	665	591	520	423	288	135	26	13	8	7
100%	96%	83%	67%	49%	35%	26%	20%	15%	13%	11%	10%	9%	7%	5%	2%	0%	0%	0%	0%

Intensities in 270° c-plane

0°	2°	4°	6°	8°	10°	12°	14°	16°	18°	20°	22°	24°	26°	28°	30°	32°	34°	36°	38°
6100	5853	5134	4099	2992	2110	1504	1128	893	747	645	573	506	417	275	131	45	12	8	6
100%	96%	84%	67%	49%	35%	25%	18%	15%	12%	11%	9%	8%	7%	5%	2%	1%	0%	0%	0%

Beam angle 50%	Field angle 10%	Cutoff angle 2,5%	Intensity ratio in 120° cone	Intensity ratio in 90° cone
15.7°	43°	60.4°	98.9%	98.4%

LAMPS (number of lamps)
50

Light planning Luminaire budgetary diagram

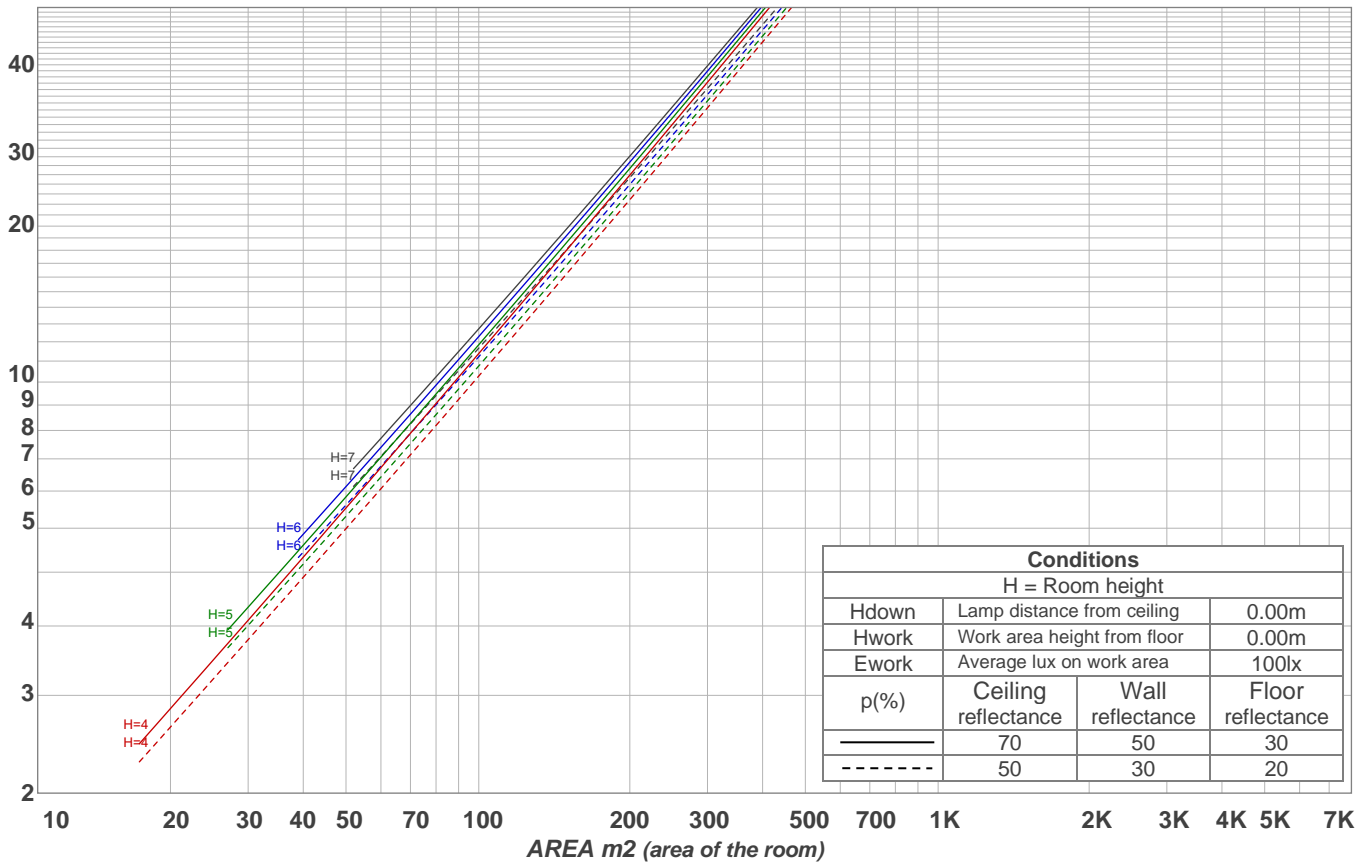

Luminaire budgetary diagram AREA m2 (area of the room) Coefficients of Utilization

Ceiling reflectance	80				70				50			30			10			0
Wall reflectance	70	50	30	10	70	50	30	10	50	30	10	50	30	10	50	30	10	0
Floor reflectance	20	20	20	20	20	20	20	20	20	20	20	20	20	20	20	20	20	0
RCR	(RCR: Room Cavity Ratio)																	
	Room Values are expressed as percentage of Lumens delivered to the task surface																	
0	119	119	119	119	116	116	116	116	111	111	111	106	106	106	102	102	102	100
1	115	113	111	109	112	110	109	107	106	105	104	103	102	101	99	99	98	96
2	111	107	104	102	109	106	103	100	102	100	98	100	98	96	97	96	94	93
3	107	103	99	96	106	101	98	95	99	96	94	97	94	92	94	93	91	90
4	104	99	95	92	103	98	94	91	96	92	90	94	91	89	92	90	88	87
5	101	95	91	88	100	94	90	87	93	89	87	91	88	86	90	87	85	84
6	98	92	88	85	97	91	87	84	90	86	84	89	86	83	87	85	83	82
7	95	89	85	82	94	88	84	81	87	84	81	86	83	81	85	82	80	79
8	93	86	82	79	92	86	82	79	85	81	79	84	81	78	83	80	78	77
9	90	84	80	77	89	83	79	77	82	79	76	82	79	76	81	78	76	75
10	88	81	77	75	87	81	77	75	80	77	74	80	77	74	79	76	74	73

Zonal Lumen Summary

0°-10°	10°-20°	20°-30°	30°-40°	40°-50°	50°-60°	60°-70°	70°-80°	80°-90°
353 lm	311 lm	209 lm	18.7 lm	3.23 lm	2.76 lm	2.95 lm	3.23 lm	3.56 lm
90°-100°	100°-110°	110°-120°	120°-130°	130°-140°	140°-150°	150°-160°	160°-170°	170°-180°
0.000 lm	0.000 lm	0.000 lm	0.000 lm	0.000 lm	0.000 lm	0.000 lm	0.000 lm	0.000 lm