

Light efficiency:



Output: 1896 lm

Light quality:



Peak: 7337 cd

Power: 20.7 W

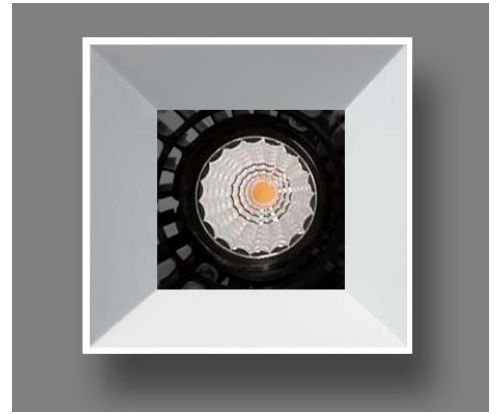

Beam angle

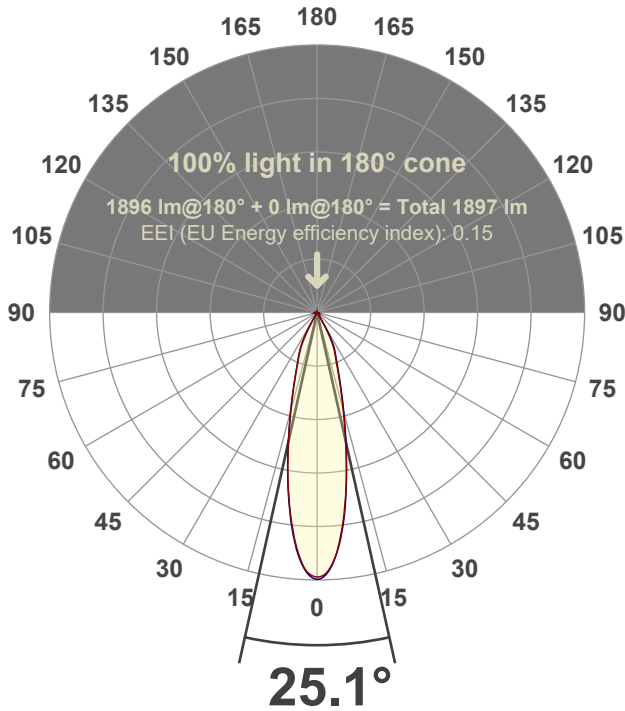

Test number:

GR-O-F-CZ20-30k-NF-SQ-Rev2

Luminaire Model:

Graffiti Open Square Fixed Downlight-CZ20 30k 24° Optic

Date and time:

6/30/2022 8:56:23 PM

Delivered Lumens

1896

Spectra

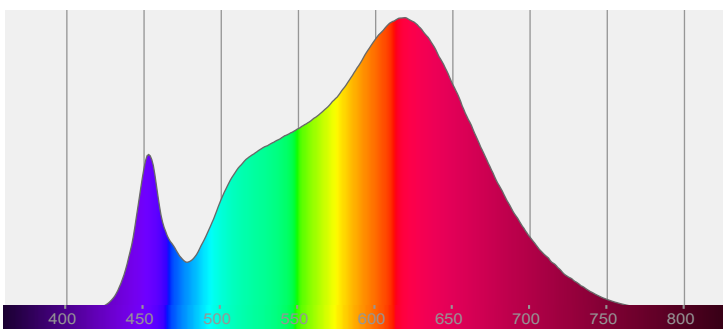

CRI: 93.2 (R1-R8)

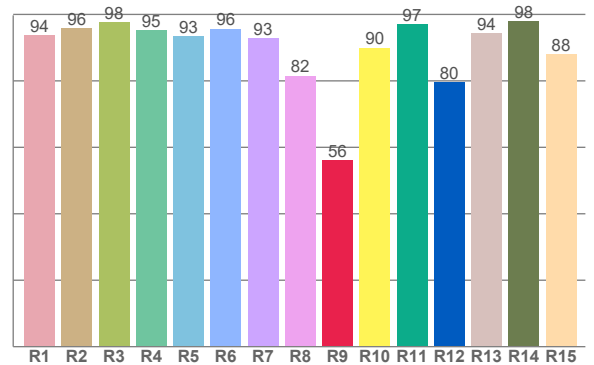

Color parameters

	Color rendering index	Red component	Color fidelity	Color gamut	Color quality scale	Color coordinate cie 1931	Color coordinate cie 1931	Color coordinate	Color coordinate	Color deviation from black body
	CRI	CRI R9	TM30 R _f	TM30 R _g	CQS	x	y	u	v	Δuv
	93.2	56.1	92.1	99.1	91.6	0.437	0.408	0.249	0.349	0.0016

R_f 92.1
Fidelity index R_f

R_g 99.1
Gammut index R_g

TM30: 92.1

TM-30Color

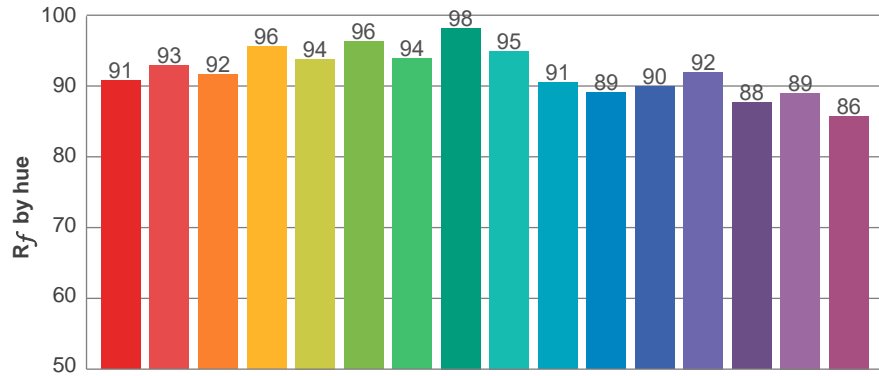

Hue Bin	R_f	Graphic shifts (%)	
		Chroma	Hue
1	91	-5%	0%
2	93	-3%	2%
3	92	-1%	4%
4	96	-1%	2%
5	94	-2%	2%
6	96	2%	1%
7	94	-2%	-1%
8	98	0%	0%
9	95	-2%	3%
10	91	-1%	5%
11	89	1%	8%
12	90	5%	1%
13	92	3%	-5%
14	88	4%	-9%
15	89	-1%	-7%
16	86	-2%	-11%

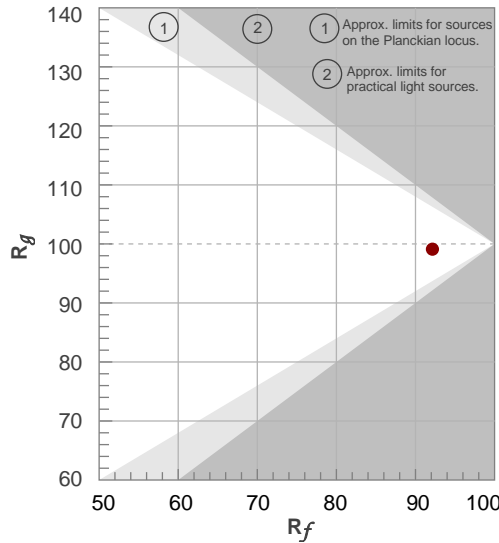

Color vector graphics

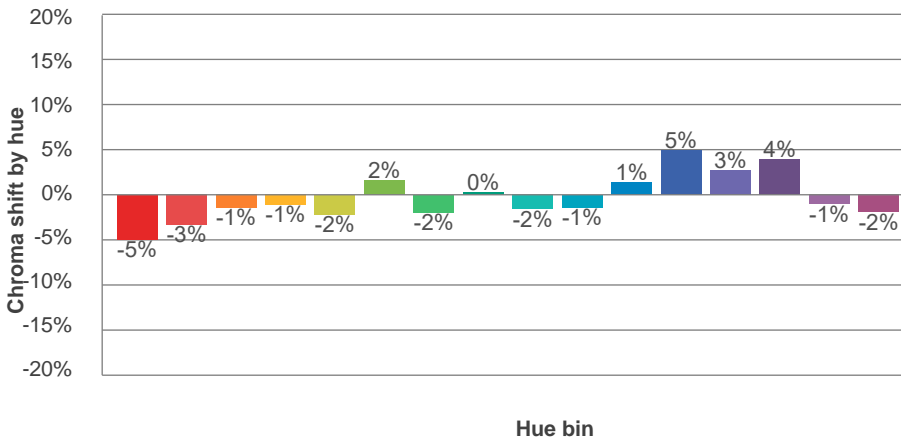
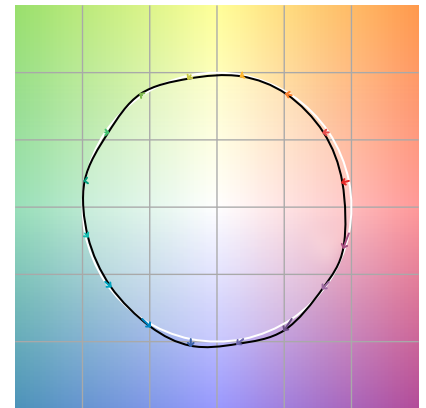

Color distortion

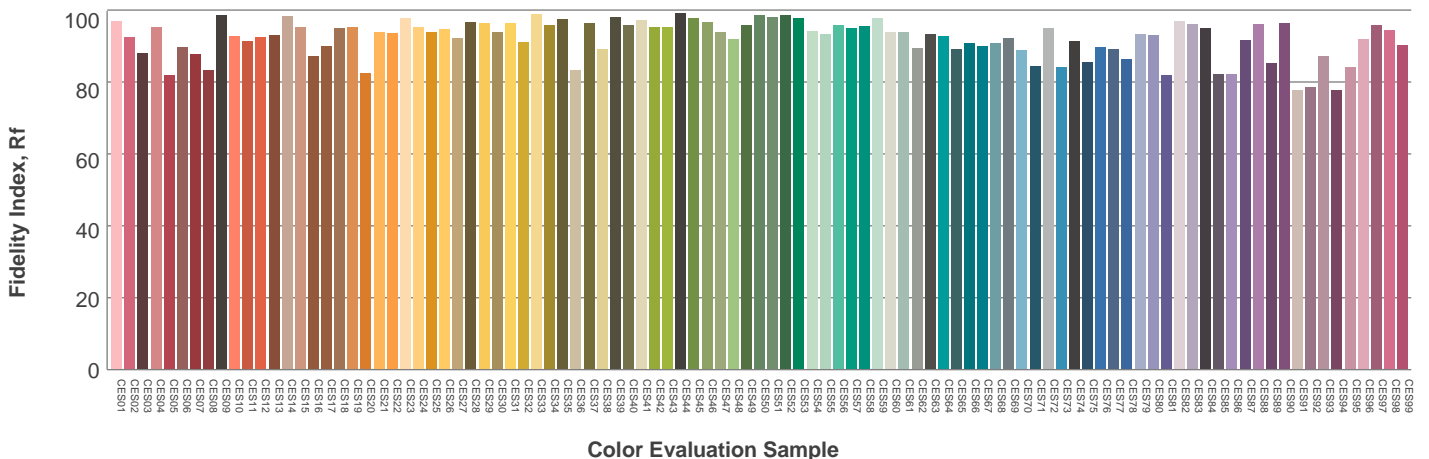

Beam details

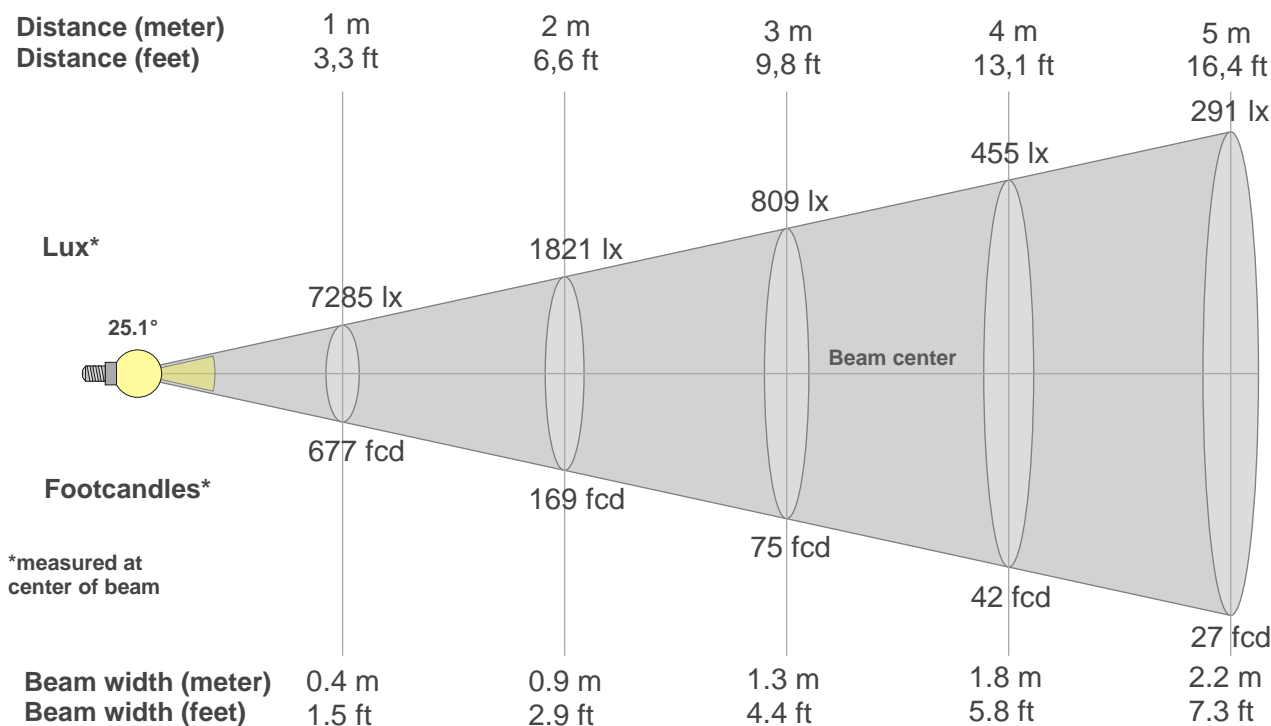

Beam intensities from 1-20m

1m	2m	3m	4m	5m	6m	7m	8m	9m	10m	11m	12m	13m	14m	15m	16m	17m	18m	19m	20m
3.3ft	6.6ft	9.8ft	13.1ft	16.4ft	19.7ft	23ft	26.2ft	29.5ft	32.8ft	36.1ft	39.4ft	42.7ft	45.9ft	49.2ft	52.5ft	55.8ft	59.1ft	62.3ft	65.6ft
7285lx	1821lx	809lx	455lx	291lx	202lx	149lx	114lx	90lx	73lx	60lx	51lx	43lx	37lx	32lx	28lx	25lx	22lx	20lx	18lx
676.8fcd	169.2fcd	75.2fcd	42.3fcd	27.1fcd	18.8fcd	13.8fcd	10.6fcd	8.4fcd	6.8fcd	5.6fcd	4.7fcd	4fcd	3.5fcd	3fcd	2.6fcd	2.3fcd	2.1fcd	1.9fcd	1.7fcd

Intensities in 0° c-plane

0°	2°	4°	6°	8°	10°	12°	14°	16°	18°	20°	22°	24°	26°	28°	30°	32°	34°	36°	38°
7285	7169	6776	6169	5437	4644	3839	3108	2524	2046	1670	1391	1189	990	704	398	156	31	18	14
100%	98%	93%	85%	75%	64%	53%	43%	35%	28%	23%	19%	16%	14%	10%	5%	2%	0%	0%	0%

Intensities in 90° c-plane

0°	2°	4°	6°	8°	10°	12°	14°	16°	18°	20°	22°	24°	26°	28°	30°	32°	34°	36°	38°
7285	7167	6791	6221	5501	4662	3882	3187	2590	2101	1719	1442	1246	1066	835	541	248	68	23	14
100%	98%	93%	85%	76%	64%	53%	44%	36%	29%	24%	20%	17%	15%	11%	7%	3%	1%	0%	0%

Intensities in 180° c-plane

0°	2°	4°	6°	8°	10°	12°	14°	16°	18°	20°	22°	24°	26°	28°	30°	32°	34°	36°	38°
7285	7125	6735	6138	5416	4639	3847	3159	2568	2077	1690	1417	1218	1004	736	430	156	36	19	14
100%	98%	92%	84%	74%	64%	53%	43%	35%	29%	23%	19%	17%	14%	10%	6%	2%	0%	0%	0%

Intensities in 270° c-plane

0°	2°	4°	6°	8°	10°	12°	14°	16°	18°	20°	22°	24°	26°	28°	30°	32°	34°	36°	38°
7285	7199	6796	6189	5455	4664	3875	3125	2523	2047	1673	1383	1153	912	592	297	103	23	17	12
100%	99%	93%	85%	75%	64%	53%	43%	35%	28%	23%	19%	16%	13%	8%	4%	1%	0%	0%	0%

Beam angle 50%	Field angle 10%	Cutoff angle 2,5%	Intensity ratio in 120° cone	Intensity ratio in 90° cone
25.1°	55.9°	63.4°	99.4%	99.1%

LAMPS (number of lamps)
50

Light planning Luminaire budgetary diagram

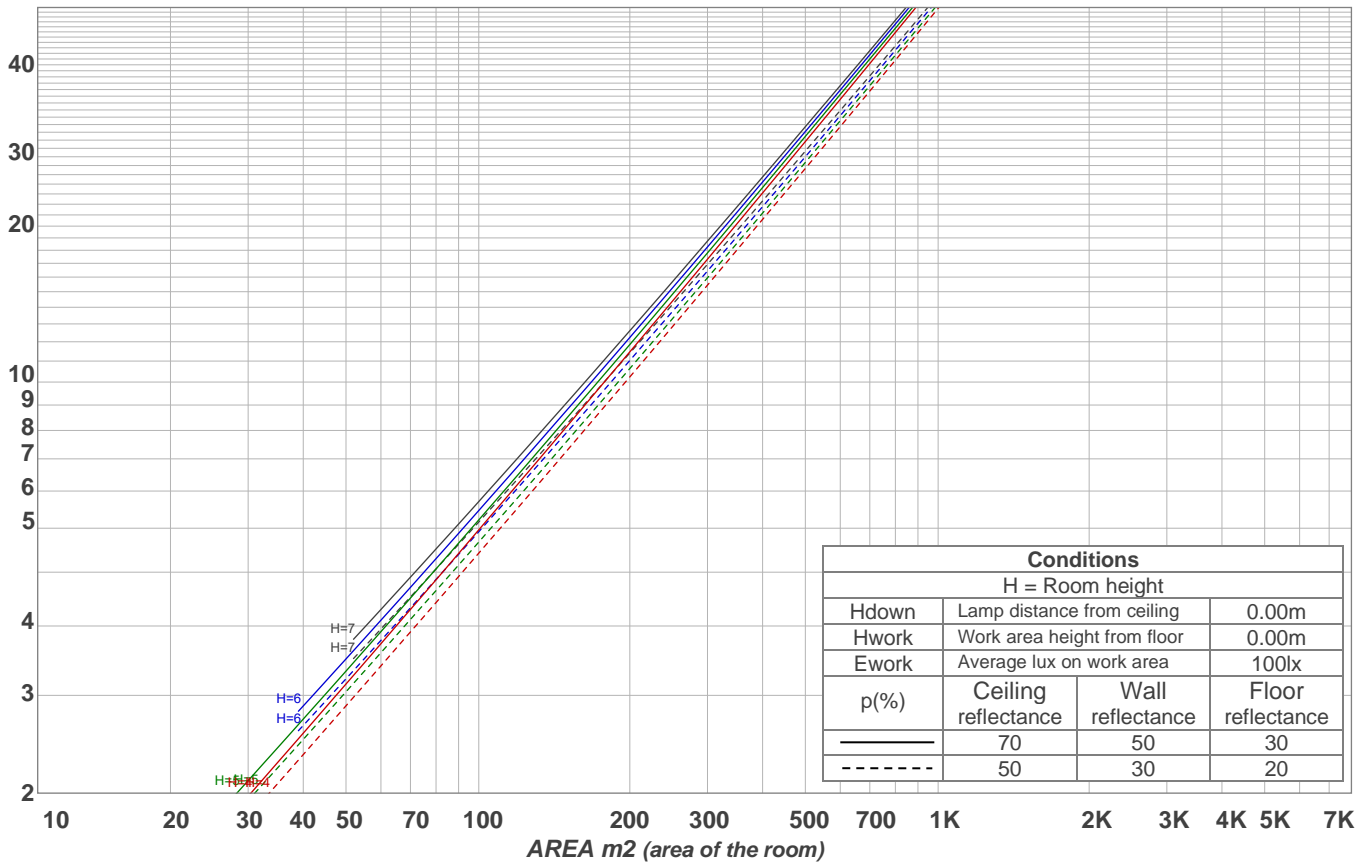

Luminaire budgetary diagram AREA m2 (area of the room) Coefficients of Utilization

Ceiling reflectance	80				70				50			30			10			0
Wall reflectance	70	50	30	10	70	50	30	10	50	30	10	50	30	10	50	30	10	0
Floor reflectance	20	20	20	20	20	20	20	20	20	20	20	20	20	20	20	20	20	0
RCR	(RCR: Room Cavity Ratio)																	
	Room Values are expressed as percentage of Lumens delivered to the task surface																	
0	119	119	119	119	116	116	116	116	111	111	111	106	106	106	102	102	102	100
1	115	112	110	109	112	110	109	107	106	105	104	103	102	101	99	98	98	96
2	111	107	104	101	109	105	102	100	102	100	98	99	97	96	96	95	94	92
3	107	102	98	95	105	101	97	94	98	95	93	96	93	91	94	92	90	89
4	103	98	93	90	102	97	93	90	95	91	89	93	90	88	91	89	87	86
5	100	94	89	86	99	93	89	86	91	88	85	90	87	84	88	86	84	82
6	97	90	86	83	96	89	85	82	88	84	82	87	84	81	86	83	81	80
7	94	87	82	79	93	86	82	79	85	81	79	84	81	78	83	80	78	77
8	91	84	80	76	90	83	79	76	82	79	76	82	78	76	81	78	75	74
9	88	81	77	74	87	81	77	74	80	76	74	79	76	73	78	75	73	72
10	86	79	74	71	85	78	74	71	77	74	71	77	73	71	76	73	71	70

Zonal Lumen Summary

0°-10°	10°-20°	20°-30°	30°-40°	40°-50°	50°-60°	60°-70°	70°-80°	80°-90°
559 lm	790 lm	480 lm	46.7 lm	4.83 lm	3.43 lm	3.27 lm	4.13 lm	4.55 lm
90°-100°	100°-110°	110°-120°	120°-130°	130°-140°	140°-150°	150°-160°	160°-170°	170°-180°
0.000 lm	0.000 lm	0.000 lm	0.000 lm	0.000 lm	0.000 lm	0.000 lm	0.000 lm	0.000 lm