

Light efficiency:



Output: 2001 lm

Light quality:



Peak: 10861 cd

Power: 20.7 W

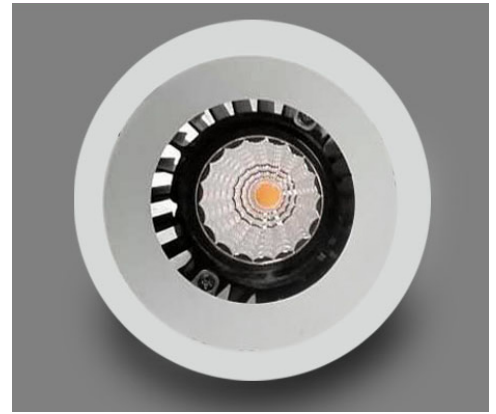

Beam angle

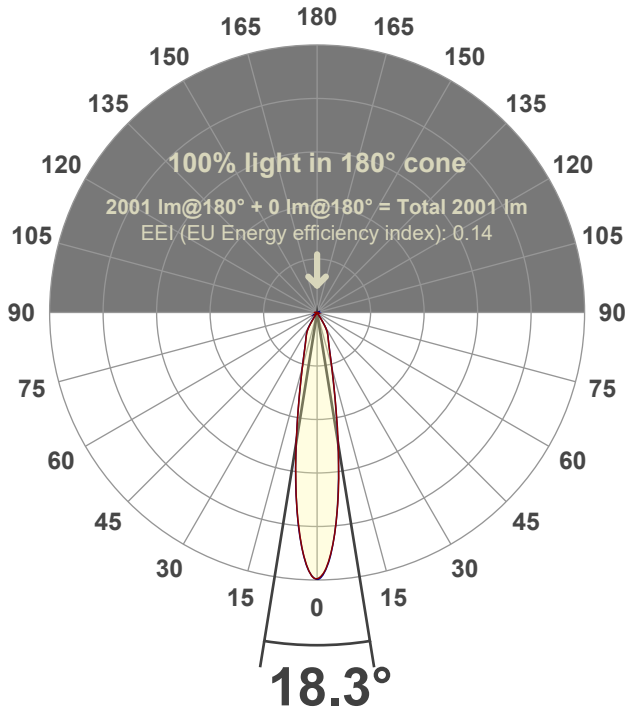

Test number:

GR-O-F-CZ20-30k-SP-RD-Rev2

Luminaire Model:

Graffiti Open Round Fixed Downlight-CZ20 30k 15° Optic

Date and time:

3/2/2022 11:14:26 PM

Delivered Lumens

2001

Spectra

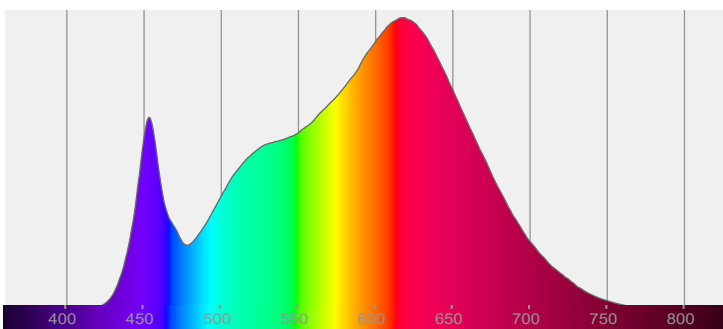

CRI: 94.3 (R1-R8)

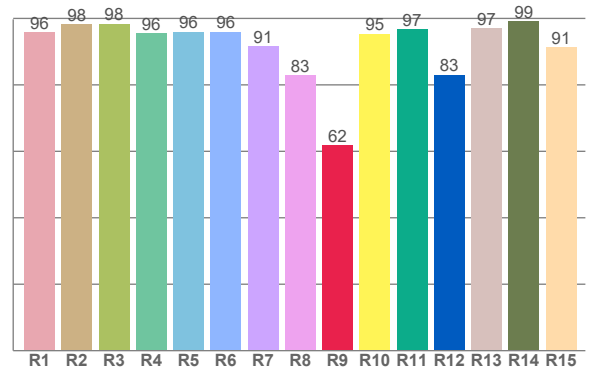

Color parameters

	Color rendering index	Red component	Color fidelity	Color gamut	Color quality scale	Color coordinate cie 1931	Color coordinate cie 1931	Color coordinate	Color coordinate	Color deviation from black body
	CRI	CRI R9	TM30 R _f	TM30 R _g	CQS	x	y	u	v	Δuv
	94.3	61.8	92.1	100.4	91.6	0.424	0.393	0.247	0.343	-0.0026

R_f 92.1
Fidelity index R_f

R_g 100.4
Gammut index R_g

TM30: 92.1

TM-30Color

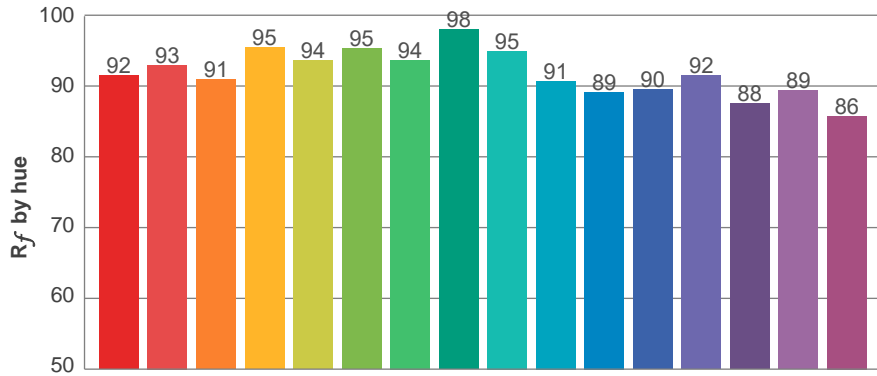

Hue Bin	R_f	Graphic shifts (%)	
		Chroma	Hue
1	92	-5%	0%
2	93	-3%	3%
3	91	-1%	5%
4	95	0%	2%
5	94	-1%	2%
6	95	2%	0%
7	94	-1%	-1%
8	98	1%	0%
9	95	-1%	3%
10	91	-1%	5%
11	89	2%	7%
12	90	6%	0%
13	92	3%	-5%
14	88	4%	-9%
15	89	-1%	-6%
16	86	-2%	-11%

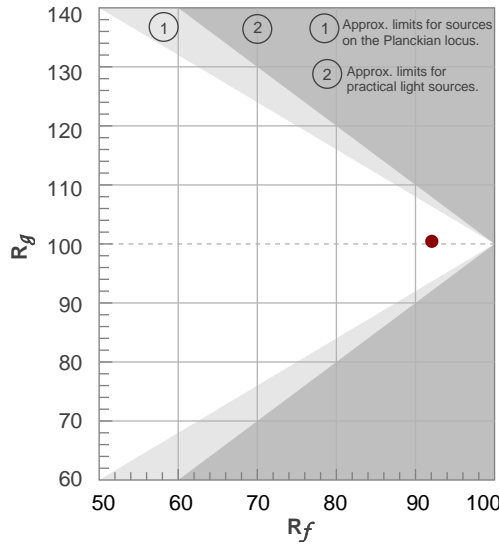

Color vector graphics

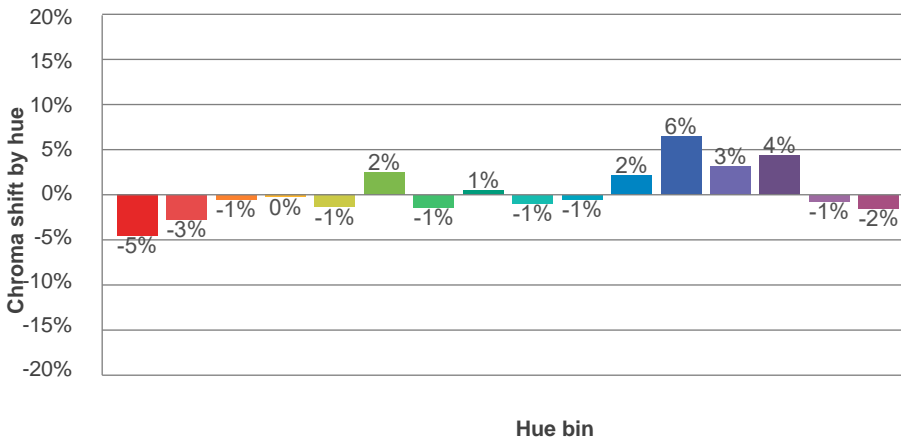
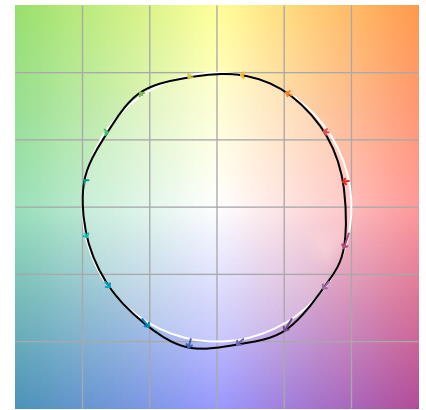

Color distortion

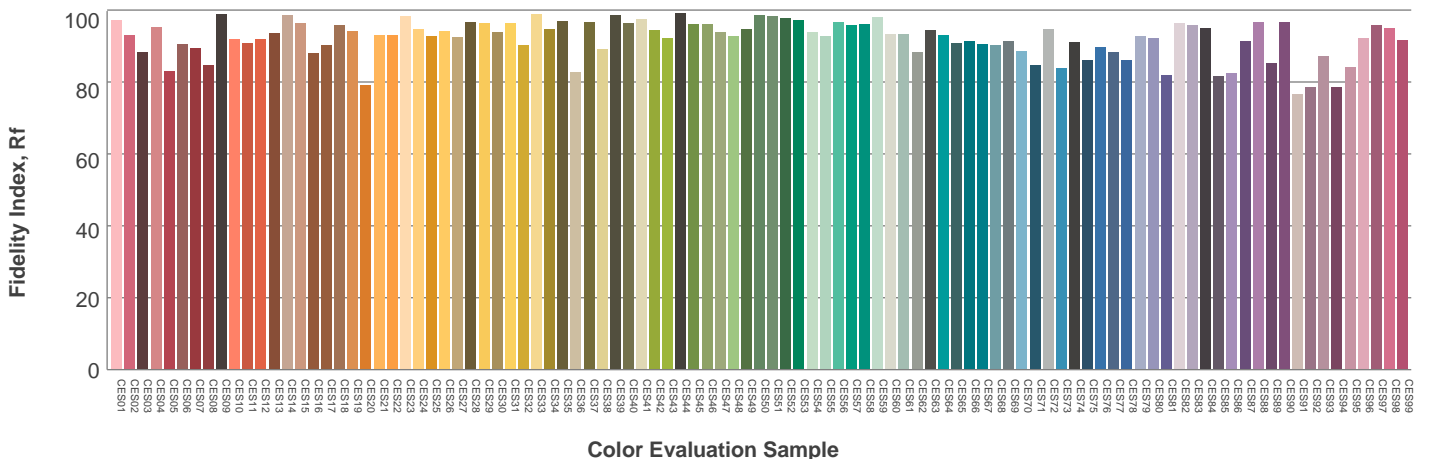

Beam details

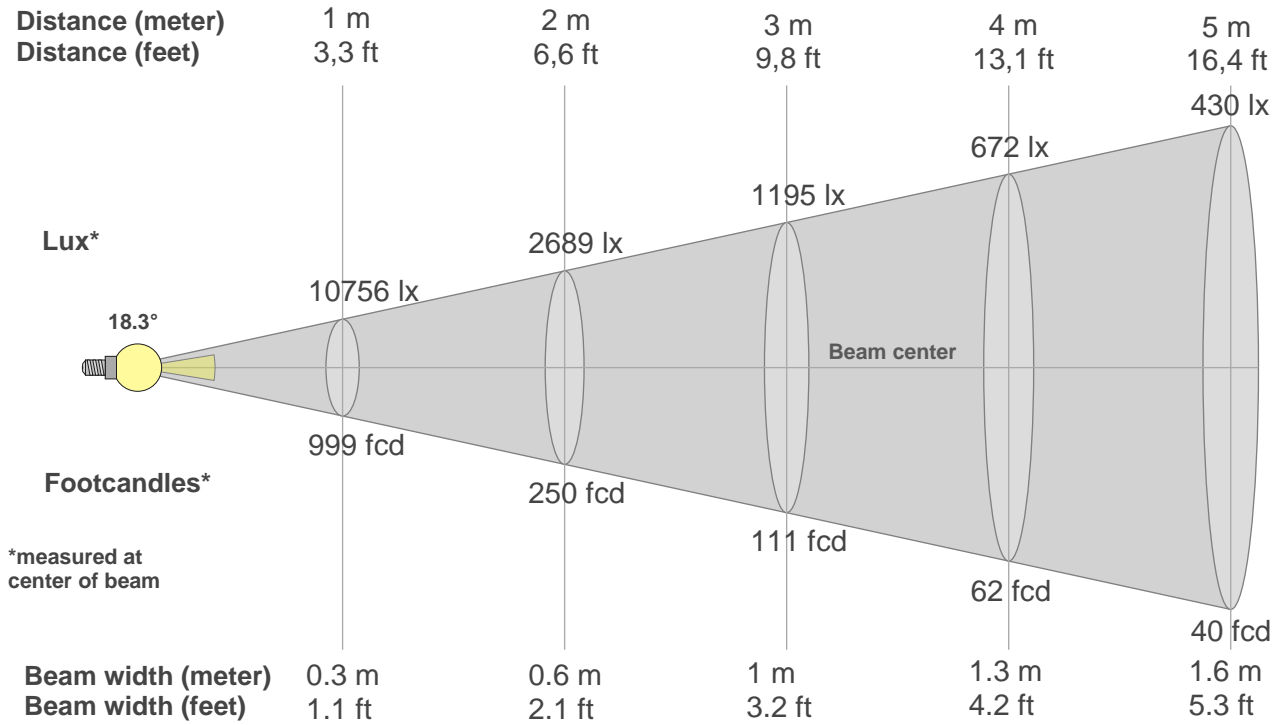

Beam intensities from 1-20m

1m	2m	3m	4m	5m	6m	7m	8m	9m	10m	11m	12m	13m	14m	15m	16m	17m	18m	19m	20m
3.3ft	6.6ft	9.8ft	13.1ft	16.4ft	19.7ft	23ft	26.2ft	29.5ft	32.8ft	36.1ft	39.4ft	42.7ft	45.9ft	49.2ft	52.5ft	55.8ft	59.1ft	62.3ft	65.6ft
10756lx	2689lx	1195lx	672lx	430lx	299lx	220lx	168lx	133lx	108lx	89lx	75lx	64lx	55lx	48lx	42lx	37lx	33lx	30lx	27lx
999.2fcd	249.8fcd	111fcd	62.5fcd	40fcd	27.8fcd	20.4fcd	15.6fcd	12.3fcd	10fcd	8.3fcd	6.9fcd	5.9fcd	5.1fcd	4.4fcd	3.9fcd	3.5fcd	3.1fcd	2.8fcd	2.5fcd

Intensities in 0° c-plane

0°	2°	4°	6°	8°	10°	12°	14°	16°	18°	20°	22°	24°	26°	28°	30°	32°	34°	36°	38°
10.8K	10.4K	9.4K	7.9K	6.4K	4.8K	3.5K	2.7K	2.1K	1.7K	1.4K	1.2K	1.1K	1.0K	0.9K	0.7K	0.5K	0.2K	0.1K	0.0K
100%	97%	87%	74%	59%	45%	33%	25%	20%	16%	13%	11%	10%	9%	8%	7%	4%	2%	1%	0%

Intensities in 90° c-plane

0°	2°	4°	6°	8°	10°	12°	14°	16°	18°	20°	22°	24°	26°	28°	30°	32°	34°	36°	38°
10.8K	10.3K	9.3K	7.9K	6.3K	4.7K	3.5K	2.7K	2.1K	1.7K	1.4K	1.2K	1.1K	1.0K	0.9K	0.7K	0.4K	0.2K	0.0K	0.0K
100%	96%	87%	74%	58%	44%	33%	25%	19%	16%	13%	12%	10%	9%	8%	6%	4%	1%	0%	0%

Intensities in 180° c-plane

0°	2°	4°	6°	8°	10°	12°	14°	16°	18°	20°	22°	24°	26°	28°	30°	32°	34°	36°	38°
10.8K	10.3K	9.4K	7.9K	6.3K	4.8K	3.6K	2.7K	2.1K	1.7K	1.4K	1.3K	1.1K	1.0K	0.9K	0.7K	0.4K	0.2K	0.0K	0.0K
100%	96%	87%	74%	59%	45%	33%	25%	19%	16%	13%	12%	10%	9%	8%	6%	4%	1%	0%	0%

Intensities in 270° c-plane

0°	2°	4°	6°	8°	10°	12°	14°	16°	18°	20°	22°	24°	26°	28°	30°	32°	34°	36°	38°
10.8K	10.4K	9.4K	7.9K	6.3K	4.7K	3.5K	2.7K	2.1K	1.7K	1.4K	1.3K	1.1K	1.0K	0.9K	0.7K	0.5K	0.2K	0.1K	0.0K
100%	97%	87%	74%	59%	44%	33%	25%	20%	16%	13%	12%	10%	9%	8%	7%	5%	2%	1%	0%

Beam angle 50%	Field angle 10%	Cutoff angle 2,5%	Intensity ratio in 120° cone	Intensity ratio in 90° cone
18.3°	48.9°	66.8°	99.3%	99.1%

LAMPS (number of lamps)
50

Light planning Luminaire budgetary diagram

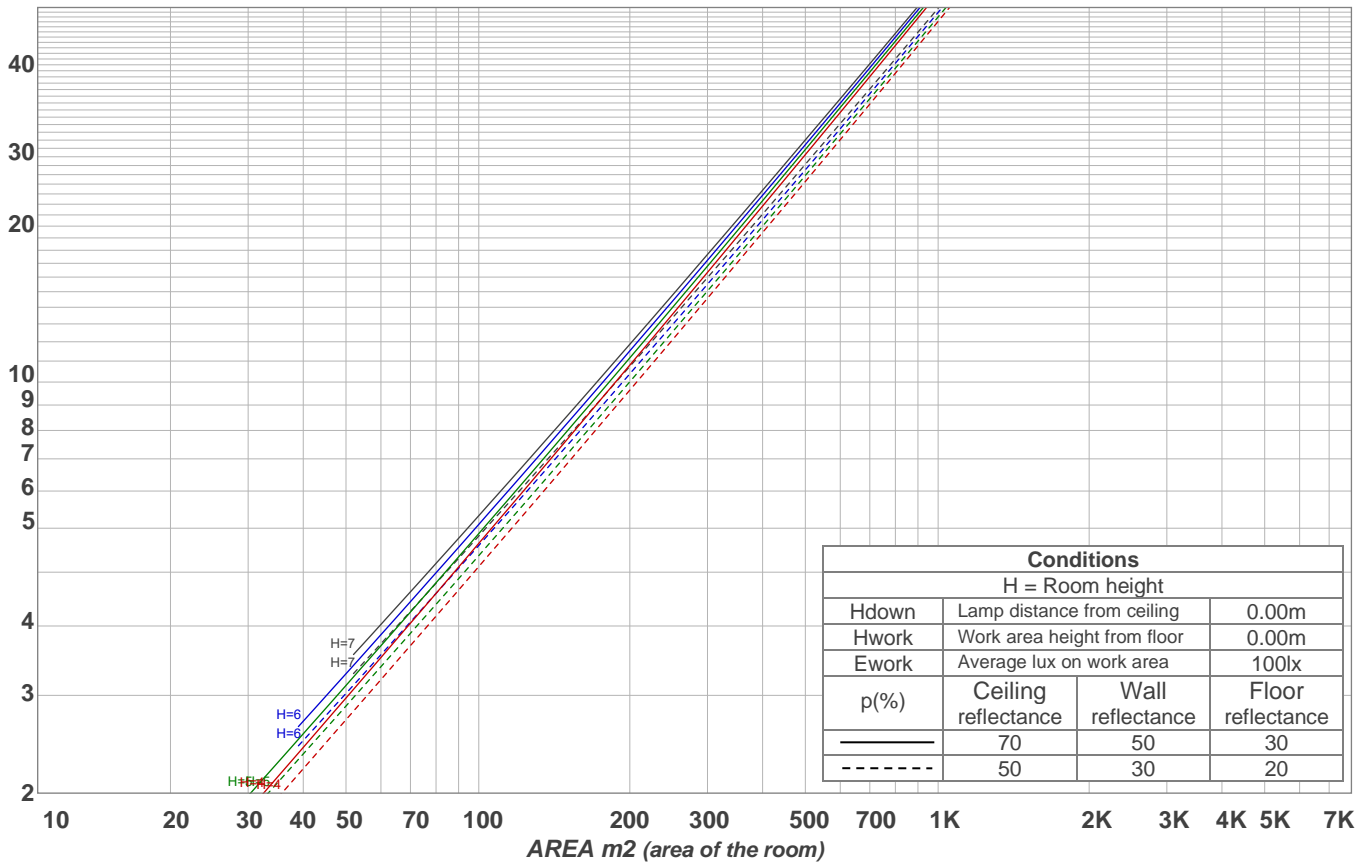

Luminaire budgetary diagram AREA m2 (area of the room) Coefficients of Utilization

Ceiling reflectance	80				70				50			30			10			0			
Wall reflectance	70	50	30	10	70	50	30	10	50	30	10	50	30	10	50	30	10	50	30	10	0
Floor reflectance	20	20	20	20	20	20	20	20	20	20	20	20	20	20	20	20	20	20	20	20	0
RCR	(RCR: Room Cavity Ratio)																				
	Room Values are expressed as percentage of Lumens delivered to the task surface																				
0	119	119	119	119	116	116	116	116	111	111	111	106	106	106	102	102	102	100	100	100	
1	115	112	110	109	112	110	109	107	106	105	104	103	102	101	99	98	98	96	96	96	
2	111	107	104	101	109	105	102	100	102	100	98	99	97	96	97	95	94	92	92	92	
3	107	102	98	95	105	101	97	94	98	95	93	96	94	92	94	92	90	89	89	89	
4	103	98	94	90	102	97	93	90	95	91	89	93	90	88	91	89	87	86	86	86	
5	100	94	90	86	99	93	89	86	91	88	85	90	87	85	88	86	84	83	83	83	
6	97	90	86	83	96	90	86	83	88	85	82	87	84	82	86	83	81	80	80	80	
7	94	87	83	80	93	87	82	80	85	82	79	84	81	79	83	81	78	77	77	77	
8	91	84	80	77	90	84	80	77	83	79	76	82	79	76	81	78	76	75	75	75	
9	89	82	77	74	88	81	77	74	80	77	74	80	76	74	79	76	74	73	73	73	
10	86	79	75	72	85	79	75	72	78	74	72	77	74	72	77	74	72	71	71	71	

Zonal Lumen Summary

0°-10°	10°-20°	20°-30°	30°-40°	40°-50°	50°-60°	60°-70°	70°-80°	80°-90°
696 lm	687 lm	479 lm	118 lm	3.51 lm	2.89 lm	3.34 lm	4.45 lm	5.81 lm
90°-100°	100°-110°	110°-120°	120°-130°	130°-140°	140°-150°	150°-160°	160°-170°	170°-180°
0.000 lm	0.000 lm	0.000 lm	0.000 lm	0.000 lm	0.000 lm	0.000 lm	0.000 lm	0.000 lm