

Light efficiency:



Light quality:



Color temperature:



Output: 844 lm
Peak: 1286 cd
Power: 15.0 W
PF: 0.98



Beam angle

51.8°

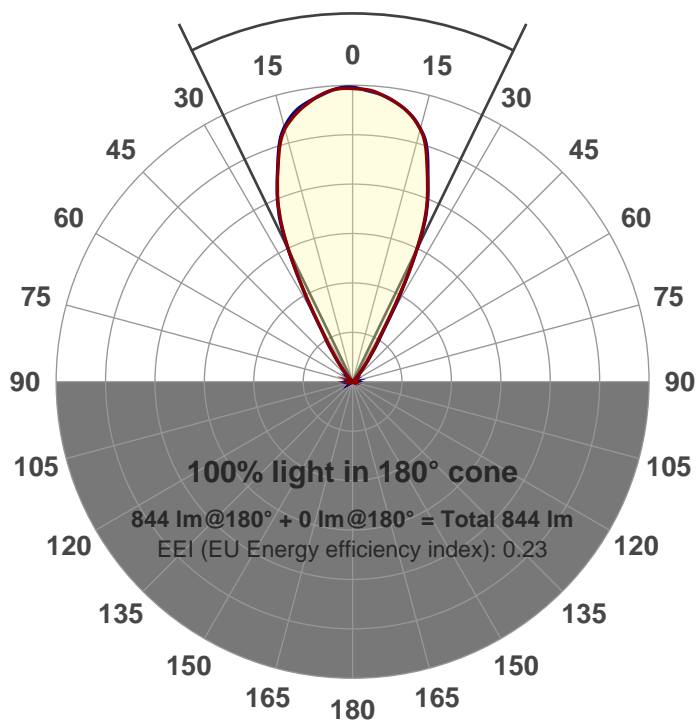

Product name:
GR-AD-WF-RD
 Item number:
GR-AD-WF-RD
 Date and time:
8/9/2017 4:48:06 PM
 Description:

LUM: 844
PPF: 15.9



CIE 1931
 x: 0.429
 y: 0.396

Spectra

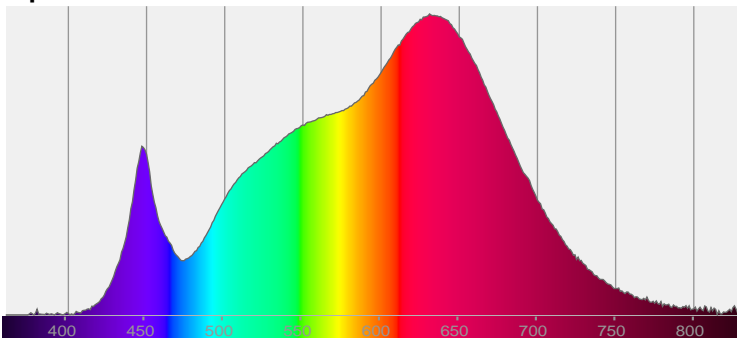

Power

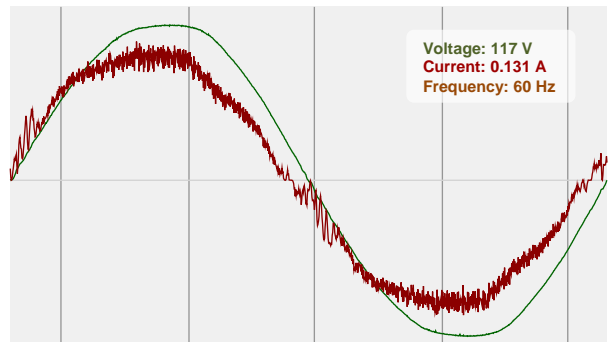

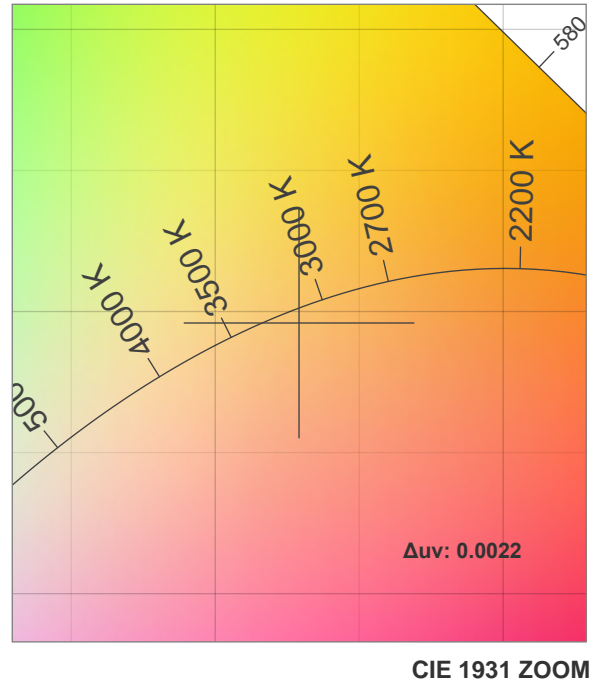
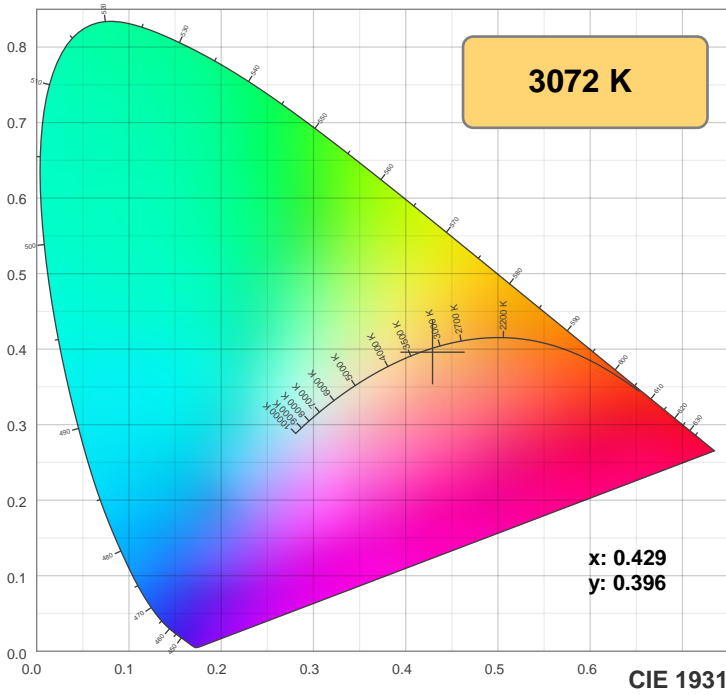

TM30: 92.6

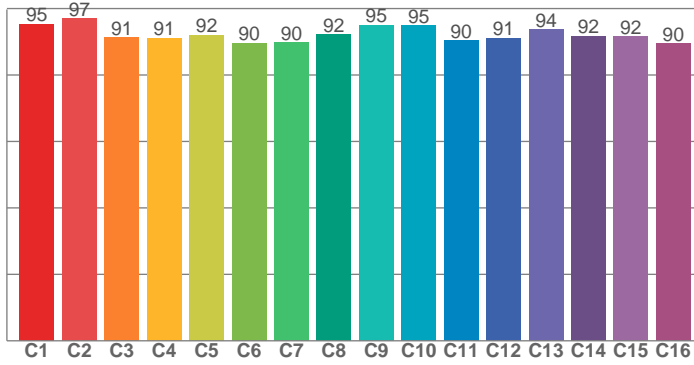

CRI: 96.5 (R1-R8)

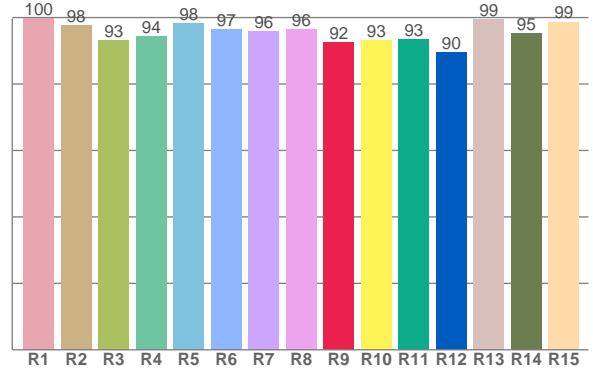

CRI R values, only R1-R8 are used to calculate final CRI value

R1	R2	R3	R4	R5	R6	R7	R8	R9	R10	R11	R12	R13	R14	R15
99.8	97.7	93.1	94.4	98.3	96.6	95.8	96.5	92.4	93.2	93.3	89.6	99.3	95.2	98.7

TM30 C values, 16 binned values out of total of 99 C values

C1	C2	C3	C4	C5	C6	C7	C8	C9	C10	C11	C12	C13	C14	C15	C16
95.3	97.0	91.3	91.1	92.0	89.7	89.8	92.3	95.1	95.0	90.4	91.1	93.7	91.7	91.7	89.6

CQS Q values

Q1	Q2	Q3	Q4	Q5	Q6	Q7	Q8	Q9	Q10	Q11	Q12	Q13	Q14	Q15
93.1	97.5	89.4	93.3	93.0	88.8	89.8	95.2	96.1	93.5	94.8	96.1	97.3	96.3	94.9

CQS: 93.2

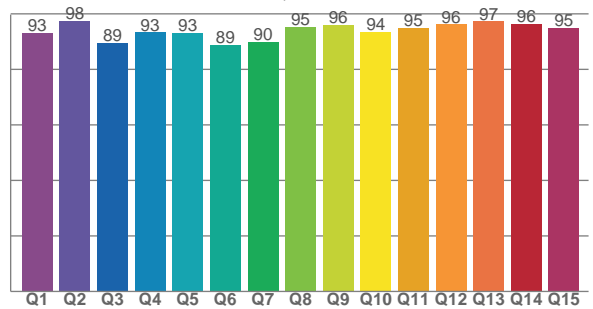

Color parameters

Color temperature	Color rendering index	Red component	Color fidelity	Color gamut	Color quality scale	Color coordinate cie 1931	Color coordinate cie 1931	Color coordinate	Color coordinate	Color deviation from black body
CCT	CRI	CRI R9	TM30 Rf	TM30 Rg	CQS	x	y	u	v	Δuv
3072 K	96.5	92.4	92.6	104.6	93.2	0.429	0.396	0.249	0.345	0.0022

TM30 details

Rf 92.6
Fidelity index Rf

Rg 104.6
Gammut index Rg

Hue Bin	R _f	Graphic shifts (%)	
		Chroma	Hue
1	95	-1%	-2%
2	97	-1%	1%
3	91	1%	4%
4	91	3%	4%
5	92	4%	4%
6	90	6%	1%
7	90	4%	-4%
8	92	2%	-4%
9	95	0%	-3%
10	95	-2%	0%
11	90	0%	5%
12	91	4%	3%
13	94	4%	0%
14	92	6%	-2%
15	92	3%	-4%
16	90	3%	-7%

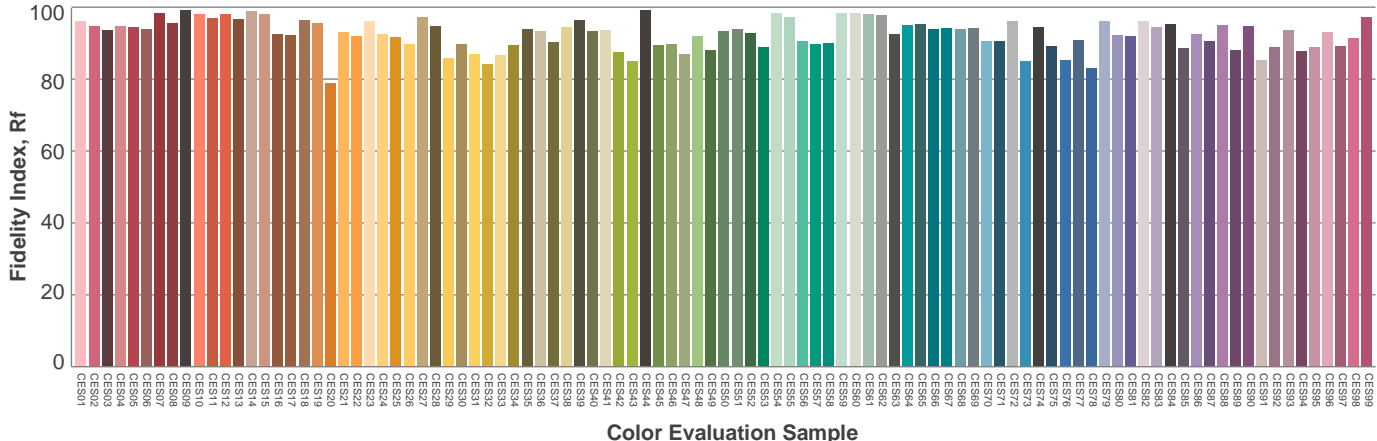
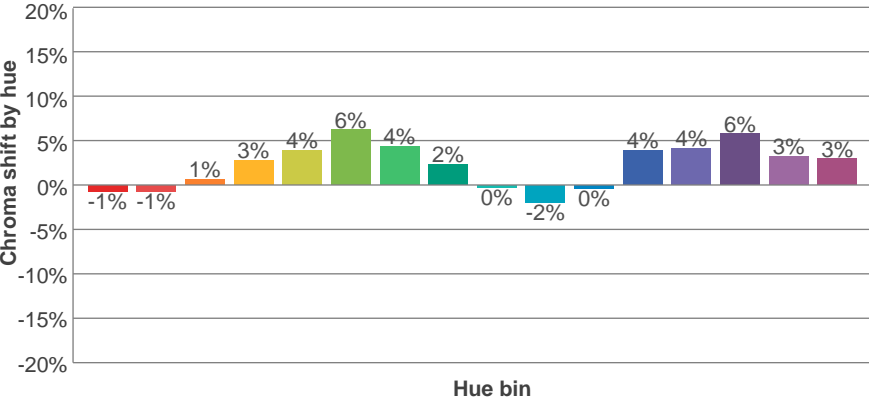
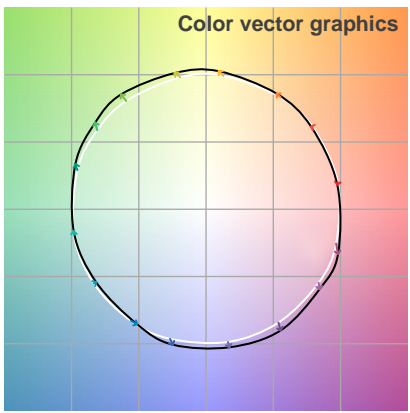
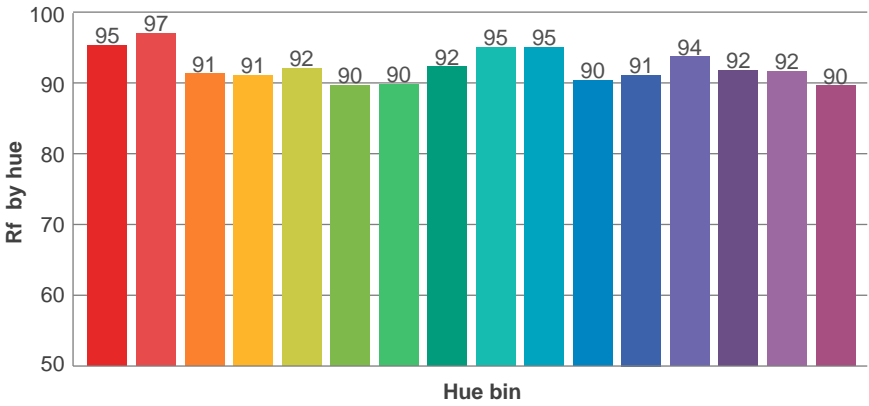
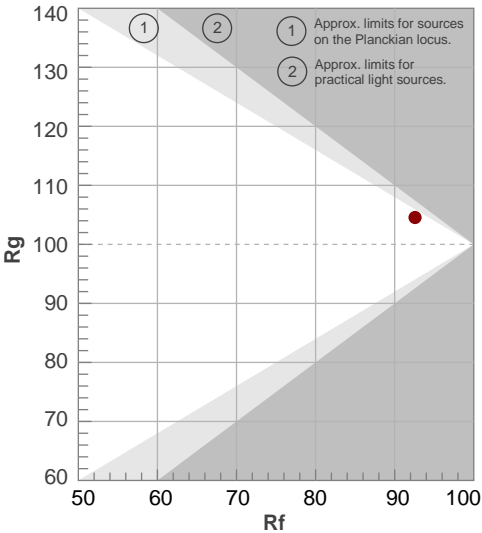

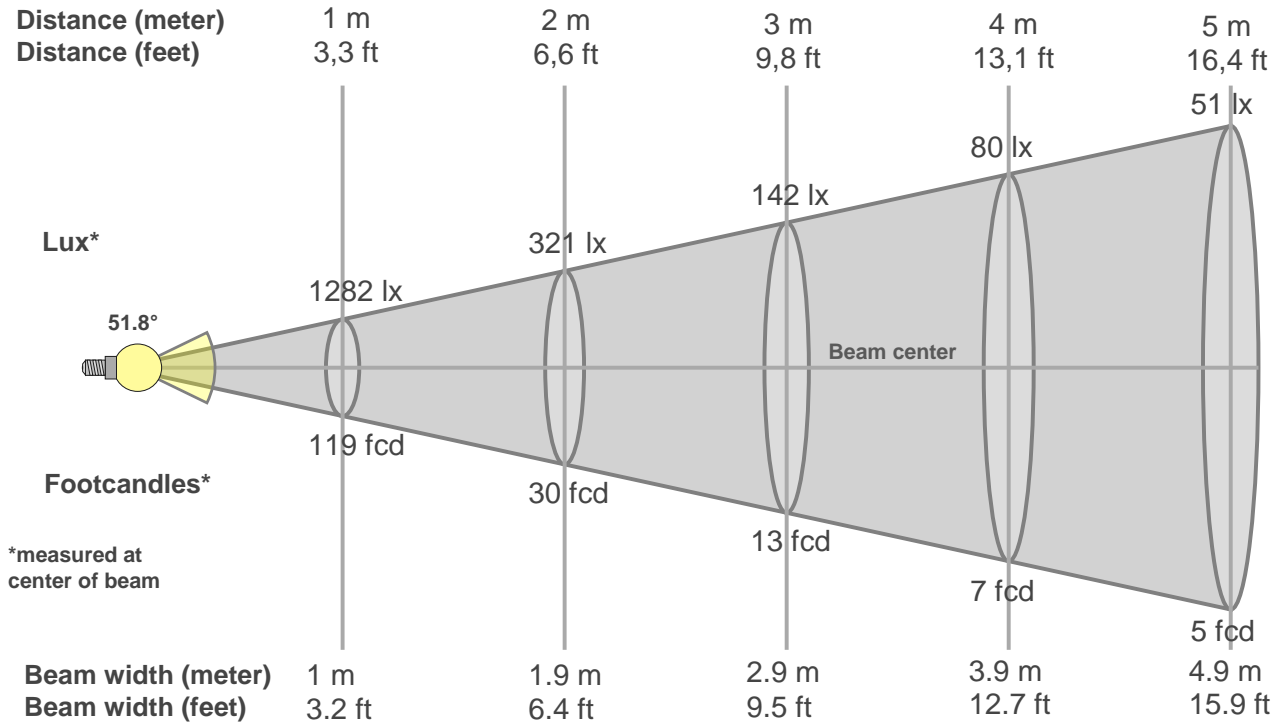

Beam intensities from 1-20m

1m	2m	3m	4m	5m	6m	7m	8m	9m	10m	11m	12m	13m	14m	15m	16m	17m	18m	19m	20m
3.3ft	6.6ft	9.8ft	13.1ft	16.4ft	19.7ft	23ft	26.2ft	29.5ft	32.8ft	36.1ft	39.4ft	42.7ft	45.9ft	49.2ft	52.5ft	55.8ft	59.1ft	62.3ft	65.6ft
1282lx	321lx	142lx	80lx	51lx	36lx	26lx	20lx	16lx	13lx	11lx	9lx	8lx	7lx	6lx	5lx	4lx	4lx	4lx	3lx
119.1fc	29.8fcd	13.2fcd	7.4fcd	4.8fcd	3.3fcd	2.4fcd	1.9fcd	1.5fcd	1.2fcd	1fcd	0.8fcd	0.7fcd	0.6fcd	0.5fcd	0.5fcd	0.4fcd	0.4fcd	0.3fcd	0.3fcd

Intensities in 0° c-plane

0°	2°	4°	6°	8°	10°	12°	14°	16°	18°	20°	22°	24°	26°	28°	30°	32°	34°	36°	38°
1282	1281	1276	1263	1243	1220	1193	1161	1115	1042	957	873	770	631	468	314	225	164	117	78
100%	100%	100%	98%	97%	95%	93%	91%	87%	81%	75%	68%	60%	49%	37%	24%	18%	13%	9%	6%

Intensities in 90° c-plane

0°	2°	4°	6°	8°	10°	12°	14°	16°	18°	20°	22°	24°	26°	28°	30°	32°	34°	36°	38°
1282	1284	1276	1260	1245	1228	1205	1171	1124	1048	960	878	781	635	470	326	218	149	104	68
100%	100%	99%	98%	97%	96%	94%	91%	88%	82%	75%	68%	61%	50%	37%	25%	17%	12%	8%	5%

Intensities in 180° c-plane

0°	2°	4°	6°	8°	10°	12°	14°	16°	18°	20°	22°	24°	26°	28°	30°	32°	34°	36°	38°
1282	1277	1272	1258	1242	1221	1196	1161	1115	1042	955	871	773	631	464	301	205	143	98	67
100%	100%	99%	98%	97%	95%	93%	91%	87%	81%	74%	68%	60%	49%	36%	23%	16%	11%	8%	5%

Intensities in 270° c-plane

0°	2°	4°	6°	8°	10°	12°	14°	16°	18°	20°	22°	24°	26°	28°	30°	32°	34°	36°	38°
1282	1276	1267	1257	1240	1221	1196	1163	1120	1054	961	878	781	635	476	328	222	157	110	72
100%	100%	99%	98%	97%	95%	93%	91%	87%	82%	75%	68%	61%	50%	37%	26%	17%	12%	9%	6%

Beam angle 50%	Field angle 10%	Cutoff angle 2,5%	Intensity ratio in 120° cone	Intensity ratio in 90° cone
51.8°	70°	83.1°	1.0%	1.0%

THIS PAGE INTENSIONALLY LEFT BLANK