

Light efficiency:

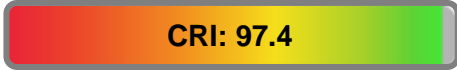

Light quality:



Color temperature:

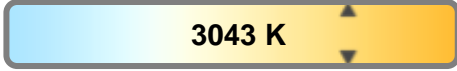

Output: 1163 lm

Peak: 2825 cd

Power: 20.7 W

PF: 0.98

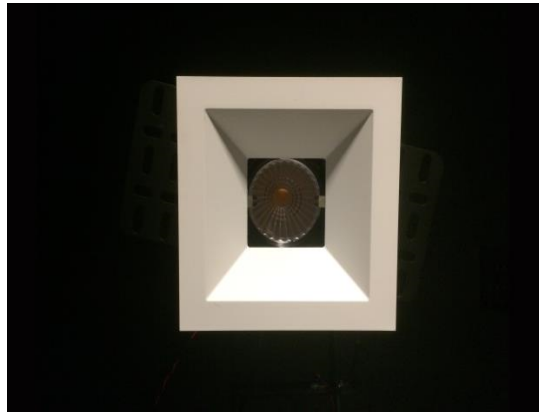

Beam angle

38.3°

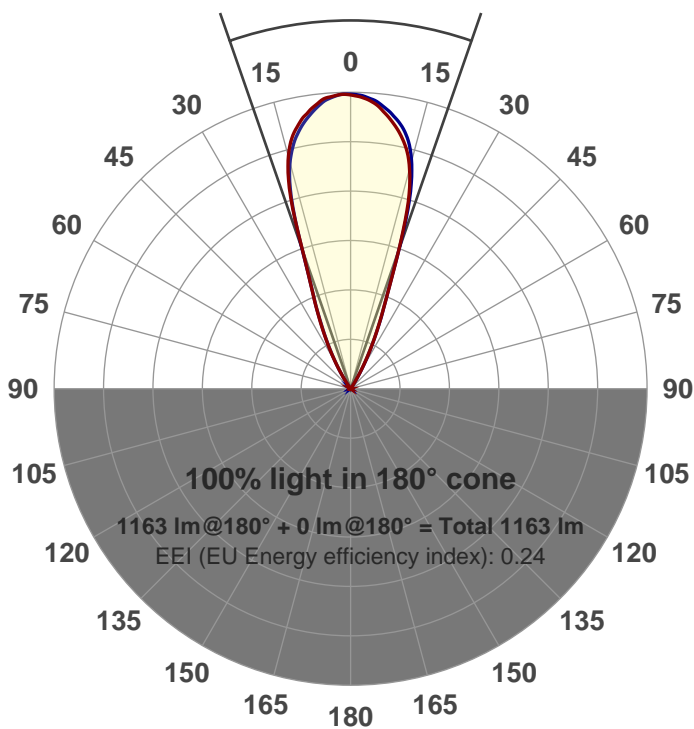

Product name:

GR-XT3017-WF-SQ

Item number:

GR-XT3017-WF-SQ

Date and time:

7/5/2017 12:36:30 PM

Description:

LUM: 1163

PPF: 22.7



CIE 1931

x: 0.433

y: 0.400

Spectra

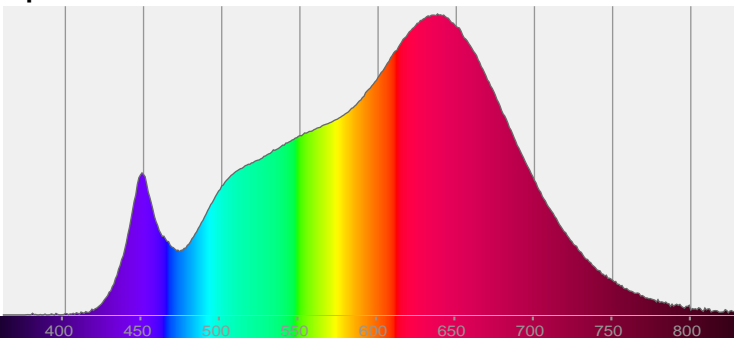

Power

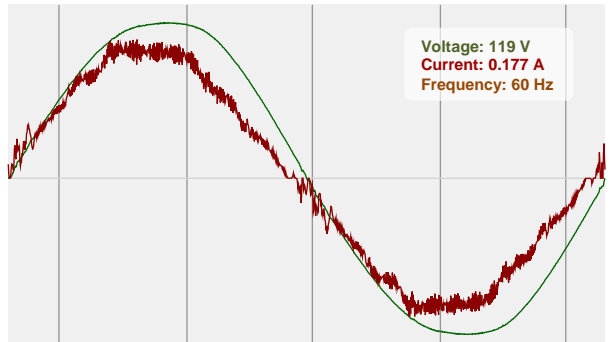

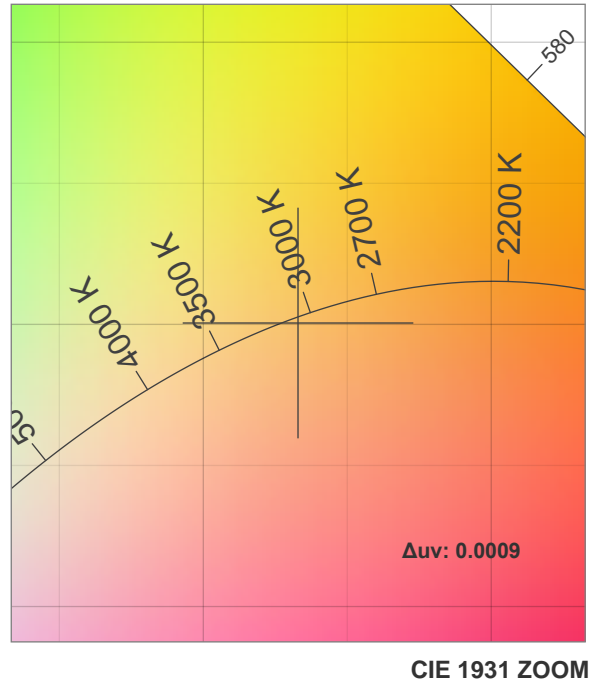
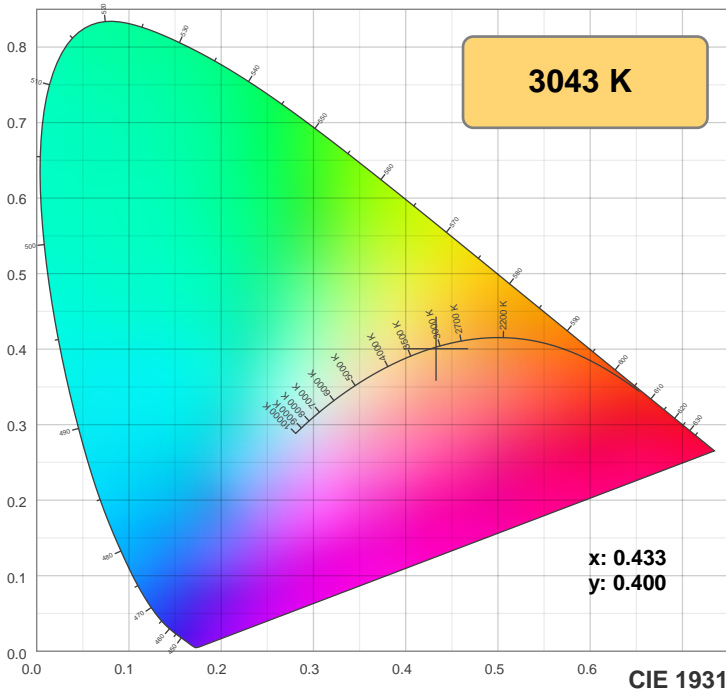

TM30: 96.0

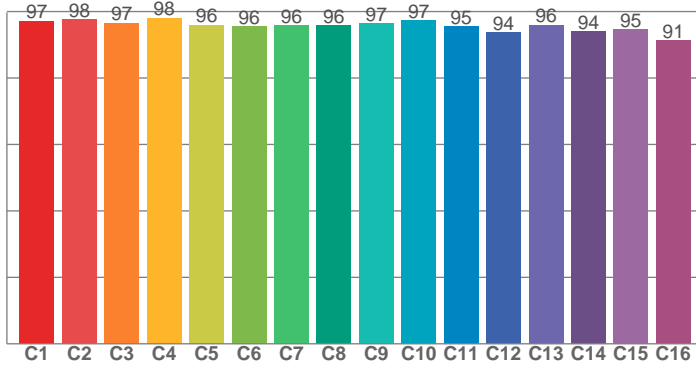

CRI: 97.4 (R1-R8)

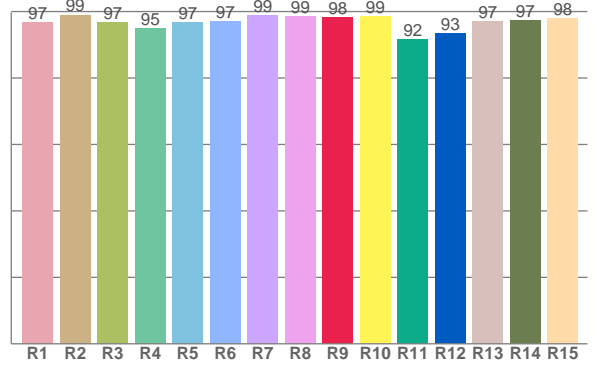

CRI R values, only R1-R8 are used to calculate final CRI value

R1	R2	R3	R4	R5	R6	R7	R8	R9	R10	R11	R12	R13	R14	R15
96.8	99.0	96.9	94.9	96.8	97.1	98.9	98.6	98.3	98.6	91.6	93.5	97.2	97.4	98.0

TM30 C values, 16 binned values out of total of 99 C values

C1	C2	C3	C4	C5	C6	C7	C8	C9	C10	C11	C12	C13	C14	C15	C16
97.1	97.7	96.6	98.1	95.9	95.6	95.8	95.8	96.5	97.4	95.5	93.6	95.9	94.1	94.6	91.2

CQS Q values

Q1	Q2	Q3	Q4	Q5	Q6	Q7	Q8	Q9	Q10	Q11	Q12	Q13	Q14	Q15
97.5	97.7	95.3	98.0	95.2	93.4	95.9	98.2	97.7	98.1	97.2	96.7	97.1	97.1	97.7

CQS: 96.4

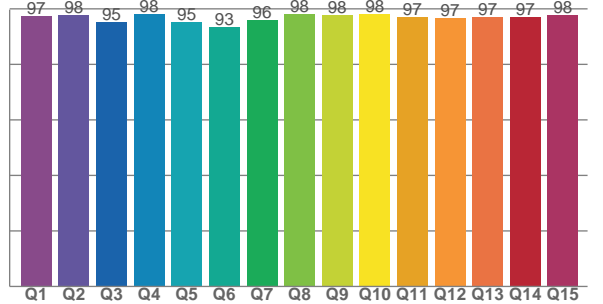

Color parameters

Color temperature	Color rendering index	Red component	Color fidelity	Color gamut	Color quality scale	Color coordinate cie 1931	Color coordinate cie 1931	Color coordinate	Color coordinate	Color deviation from black body
CCT	CRI	CRI R9	TM30 Rf	TM30 Rg	CQS	x	y	u	v	Δuv
3043 K	97.4	98.3	96.0	102.6	96.4	0.433	0.400	0.250	0.346	0.0009

TM30 details

Rf 96.0
Fidelity index Rf

Rg 102.6
Gammut index Rg

Hue Bin	R _f	Graphic shifts (%)	
		Chroma	Hue
1	97	0%	-1%
2	98	1%	-1%
3	97	1%	0%
4	98	0%	0%
5	96	-1%	1%
6	96	2%	1%
7	96	1%	1%
8	96	2%	0%
9	97	1%	0%
10	97	1%	0%
11	95	2%	2%
12	94	3%	0%
13	96	2%	-2%
14	94	3%	-3%
15	95	1%	-2%
16	91	3%	-6%

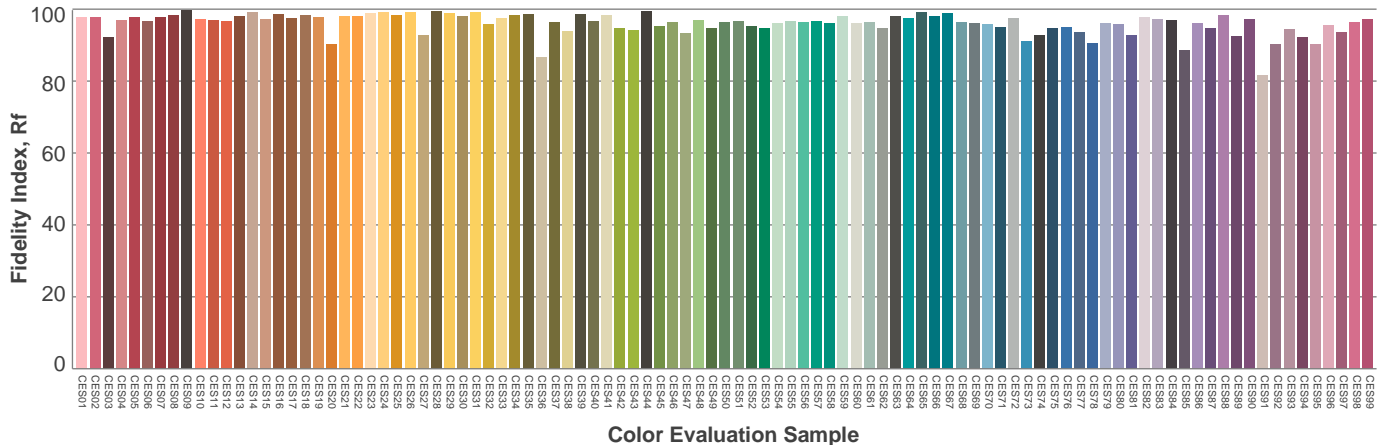
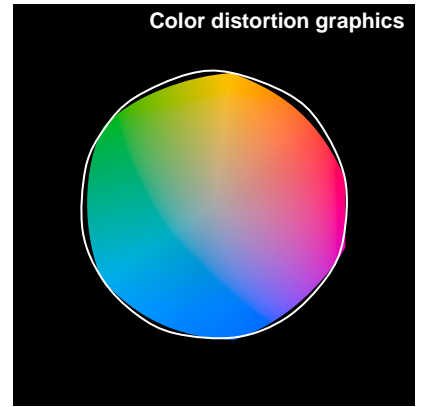
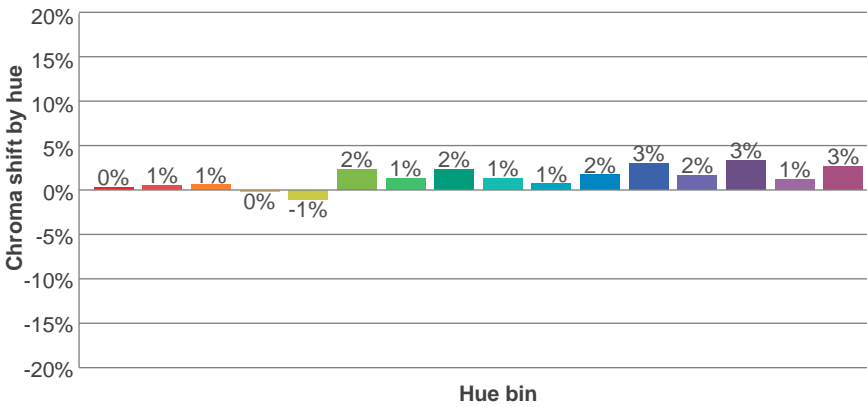
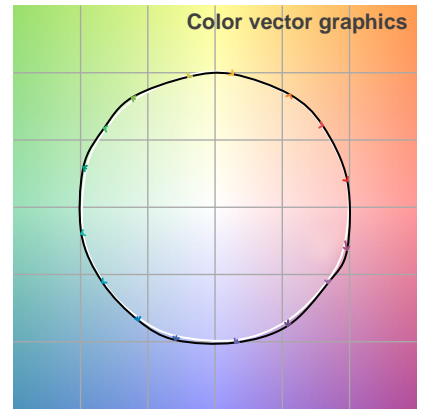
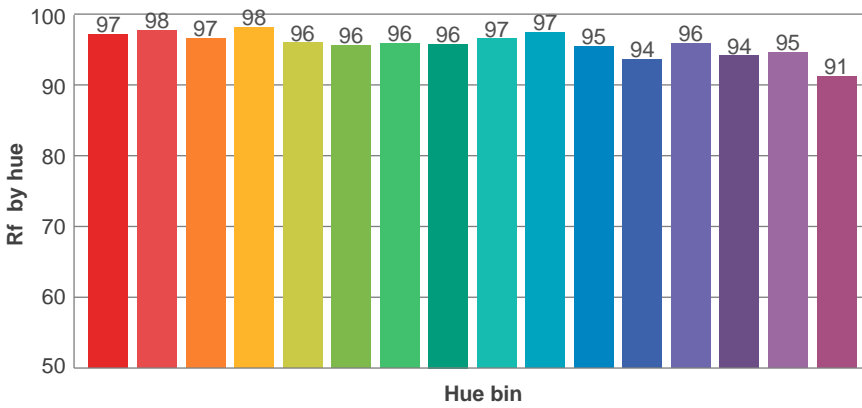
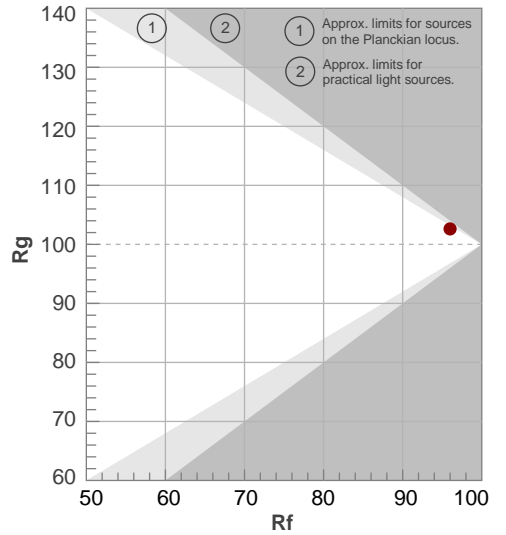

Beam details

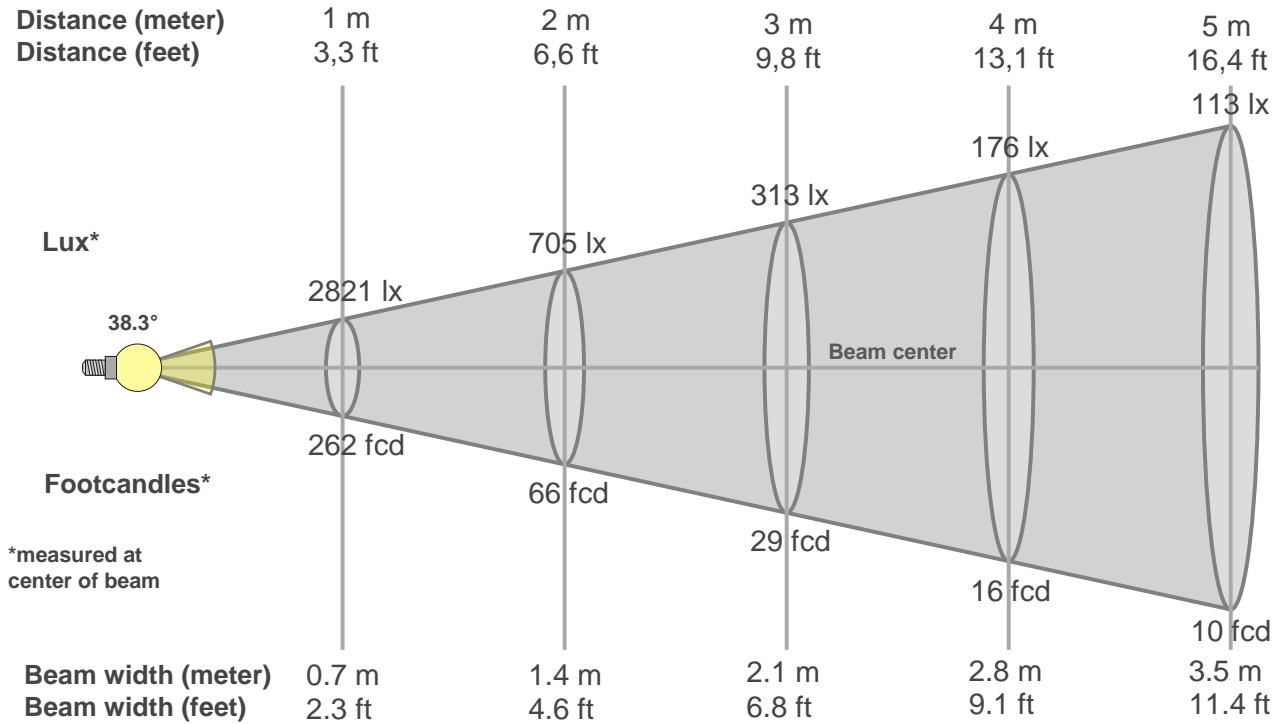

Beam intensities from 1-20m

1m	2m	3m	4m	5m	6m	7m	8m	9m	10m	11m	12m	13m	14m	15m	16m	17m	18m	19m	20m
3.3ft	6.6ft	9.8ft	13.1ft	16.4ft	19.7ft	23ft	26.2ft	29.5ft	32.8ft	36.1ft	39.4ft	42.7ft	45.9ft	49.2ft	52.5ft	55.8ft	59.1ft	62.3ft	65.6ft
2821lx	705lx	313lx	176lx	113lx	78lx	58lx	44lx	35lx	28lx	23lx	20lx	17lx	14lx	13lx	11lx	10lx	9lx	8lx	7lx
262fcd	65.5fcd	29.1fcd	16.4fcd	10.5fcd	7.3fcd	5.3fcd	4.1fcd	3.2fcd	2.6fcd	2.2fcd	1.8fcd	1.6fcd	1.3fcd	1.2fcd	1fcd	0.9fcd	0.8fcd	0.7fcd	0.7fcd

Intensities in 0° c-plane

0°	2°	4°	6°	8°	10°	12°	14°	16°	18°	20°	22°	24°	26°	28°	30°	32°	34°	36°	38°
2821	2822	2805	2773	2710	2638	2539	2404	2173	1754	1219	942	738	564	413	277	161	66	16	6
100%	100%	99%	98%	96%	94%	90%	85%	77%	62%	43%	33%	26%	20%	15%	10%	6%	2%	1%	0%

Intensities in 90° c-plane

0°	2°	4°	6°	8°	10°	12°	14°	16°	18°	20°	22°	24°	26°	28°	30°	32°	34°	36°	38°
2821	2822	2794	2745	2672	2587	2481	2337	2124	1732	1220	931	721	547	398	267	152	61	14	6
100%	100%	99%	97%	95%	92%	88%	83%	75%	61%	43%	33%	26%	19%	14%	9%	5%	2%	0%	0%

Intensities in 180° c-plane

0°	2°	4°	6°	8°	10°	12°	14°	16°	18°	20°	22°	24°	26°	28°	30°	32°	34°	36°	38°
2821	2798	2764	2707	2627	2539	2430	2285	2057	1685	1209	873	655	475	320	186	80	19	7	6
100%	99%	98%	96%	93%	90%	86%	81%	73%	60%	43%	31%	23%	17%	11%	7%	3%	1%	0%	0%

Intensities in 270° c-plane

0°	2°	4°	6°	8°	10°	12°	14°	16°	18°	20°	22°	24°	26°	28°	30°	32°	34°	36°	38°
2821	2814	2786	2743	2683	2609	2511	2364	2122	1732	1200	870	653	473	319	191	87	20	7	6
100%	100%	99%	97%	95%	92%	89%	84%	75%	61%	43%	31%	23%	17%	11%	7%	3%	1%	0%	0%

Beam angle 50%	Field angle 10%	Cutoff angle 2,5%	Intensity ratio in 120° cone	Intensity ratio in 90° cone
38.3°	58.4°	66.1°	1.0%	1.0%

THIS PAGE INTENSIONALLY LEFT BLANK