

Light efficiency:



Light quality:



Color temperature:

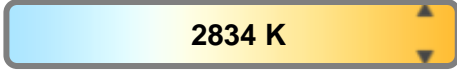

Output: 786 lm

Peak: 519 cd

Power: 21.3 W

PF: 0.99



Beam angle

69.7°

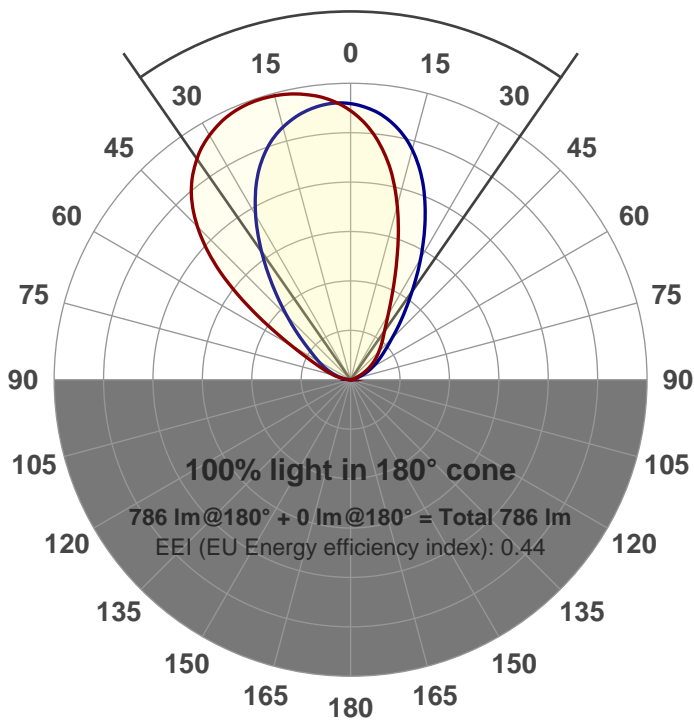

Product name:

GRWW-CZ14-SQ-27-500

Item number:

GRWW-CZ14-SQ-27-500

Date and time:

1/15/2018 2:50:52 PM

Description:

LUM: 786

PPF: 14.2



CIE 1931
x: 0.453
y: 0.416

Spectra

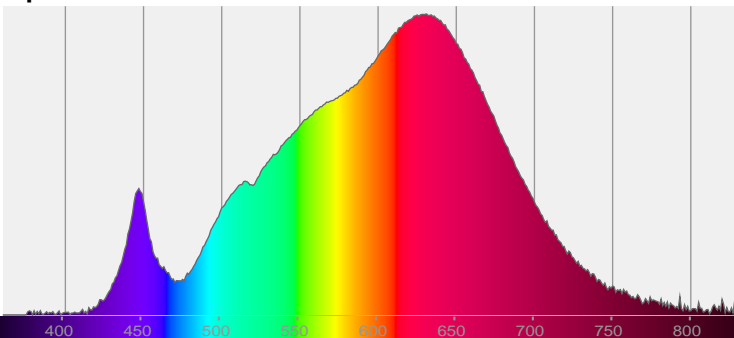

Power

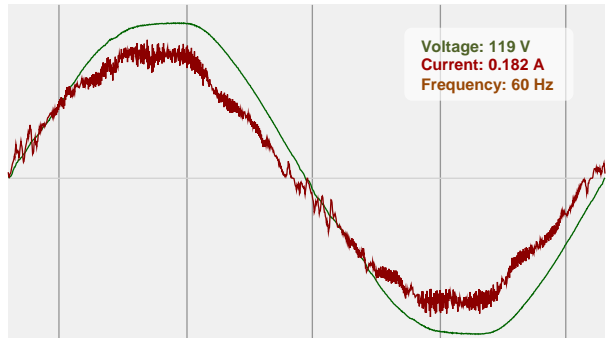

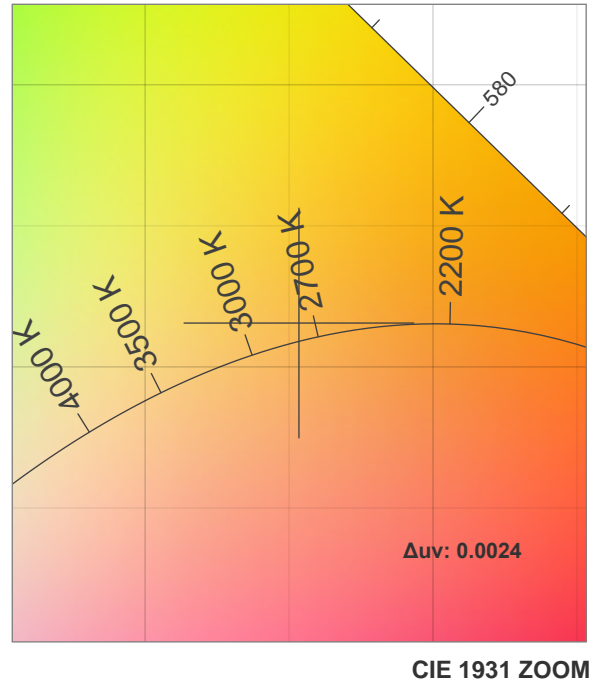
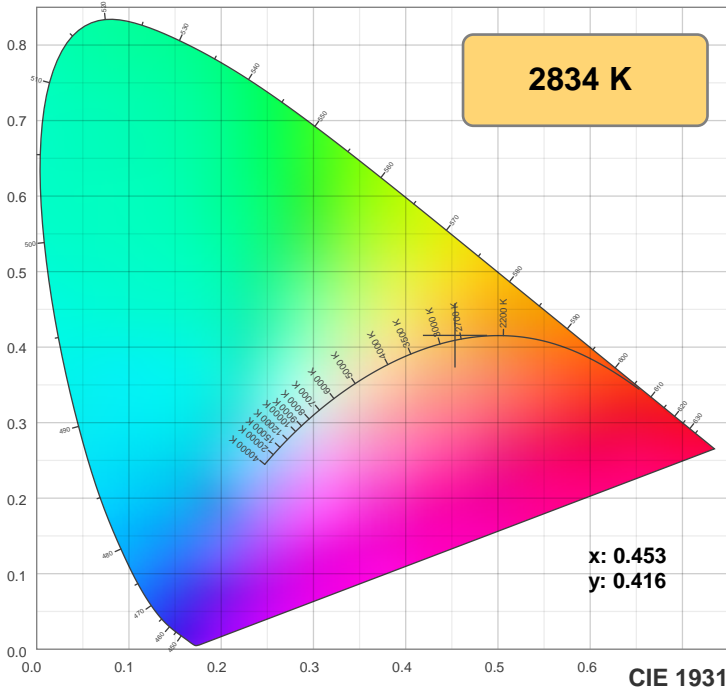

TM30: 91.0

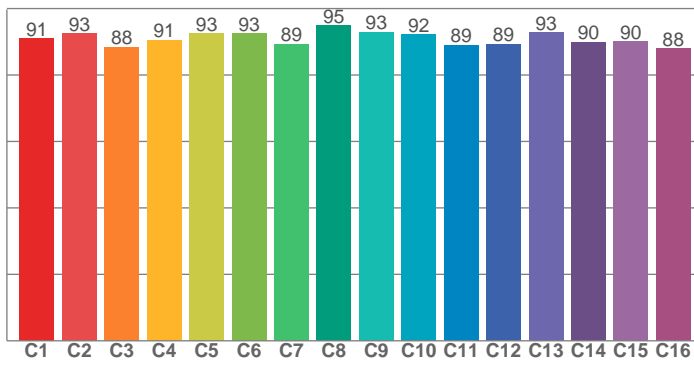

CRI: 92.3 (R1-R8)

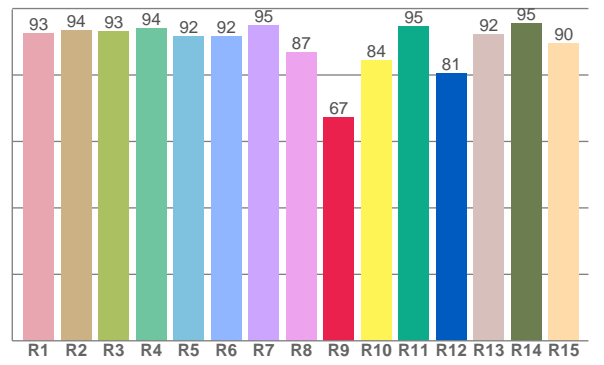

CRI R values, only R1-R8 are used to calculate final CRI value

R1	R2	R3	R4	R5	R6	R7	R8	R9	R10	R11	R12	R13	R14	R15
92.5	93.6	93.2	94.0	91.5	91.6	94.9	86.8	67.3	84.4	94.6	80.6	92.3	95.4	89.6

TM30 C values, 16 binned values out of total of 99 C values

C1	C2	C3	C4	C5	C6	C7	C8	C9	C10	C11	C12	C13	C14	C15	C16
91.0	92.6	88.5	90.6	92.5	92.5	89.3	95.0	92.9	92.1	89.0	89.4	92.9	89.9	90.2	88.0

CQS Q values

Q1	Q2	Q3	Q4	Q5	Q6	Q7	Q8	Q9	Q10	Q11	Q12	Q13	Q14	Q15
88.5	96.8	89.5	90.0	89.7	88.1	91.0	94.5	96.3	93.3	92.1	92.6	93.1	88.0	88.2

CQS: 90.9

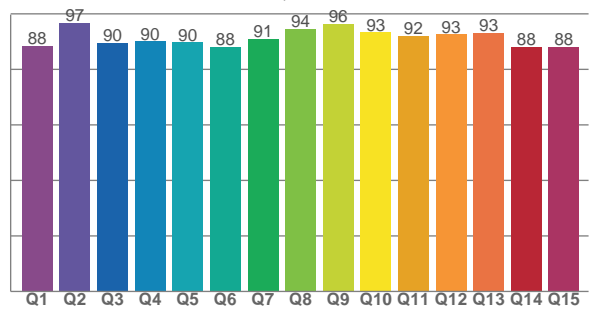

Color parameters

Color temperature	Color rendering index	Red component	Color fidelity	Color gamut	Color quality scale	Color coordinate cie 1931	Color coordinate cie 1931	Color coordinate	Color coordinate	Color deviation from black body
CCT	CRI	CRI R9	TM30 Rf	TM30 Rg	CQS	x	y	u	v	Δuv
2834 K	92.3	67.3	91.0	100.9	90.9	0.453	0.416	0.256	0.352	0.0024

TM30 details

Rf 91.0
Fidelity index Rf

Rg 100.9
Gammut index Rg

Hue Bin	R _f	Graphic shifts (%)	
		Chroma	Hue
1	91	-4%	-2%
2	93	-3%	2%
3	88	-1%	5%
4	91	2%	5%
5	93	4%	4%
6	93	4%	0%
7	89	2%	-6%
8	95	0%	-3%
9	93	-3%	-2%
10	92	-4%	1%
11	89	-2%	6%
12	89	3%	3%
13	93	4%	-2%
14	90	5%	-5%
15	90	1%	-5%
16	88	-1%	-8%

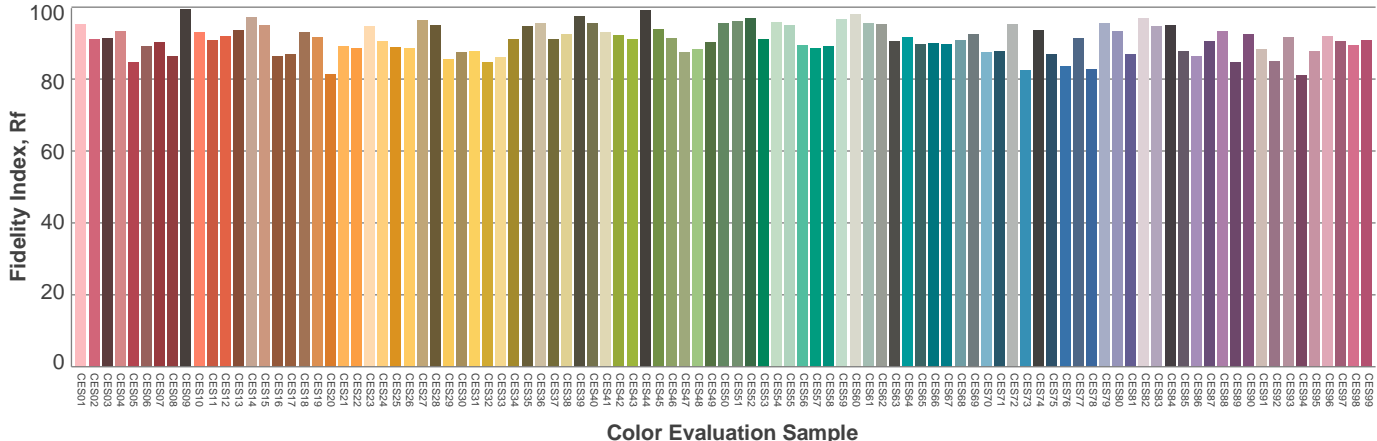
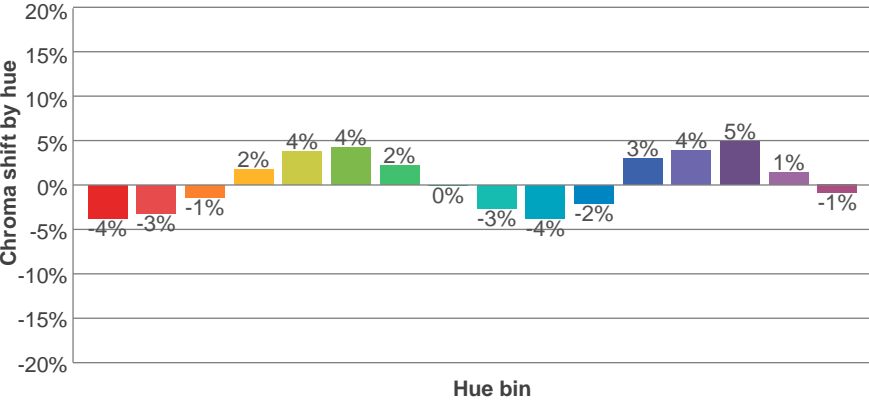
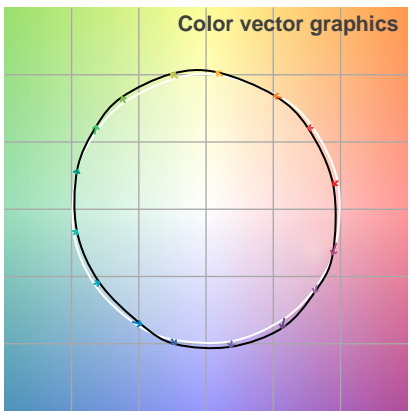
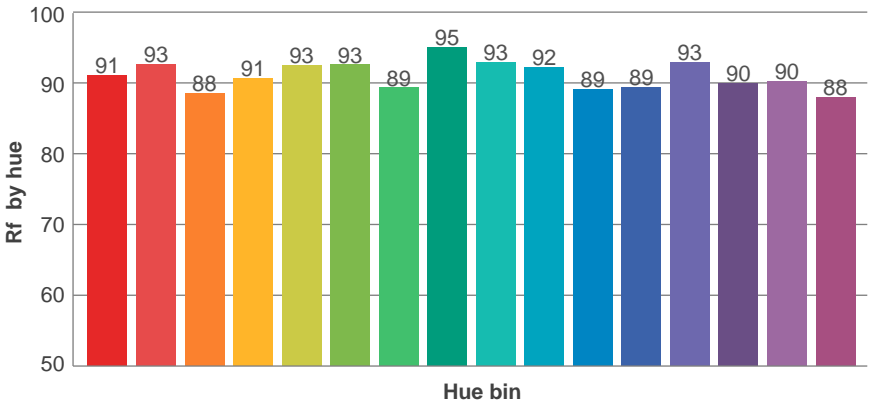
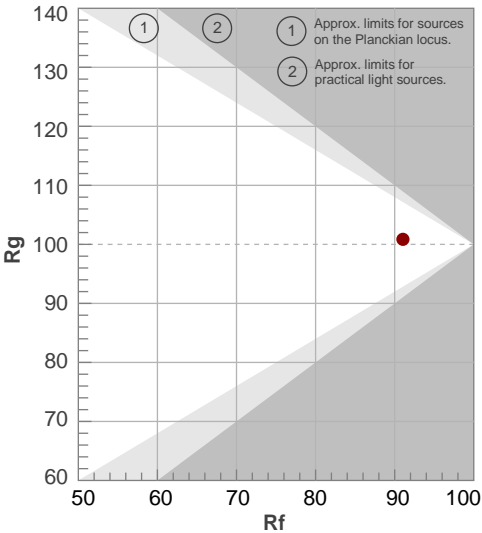

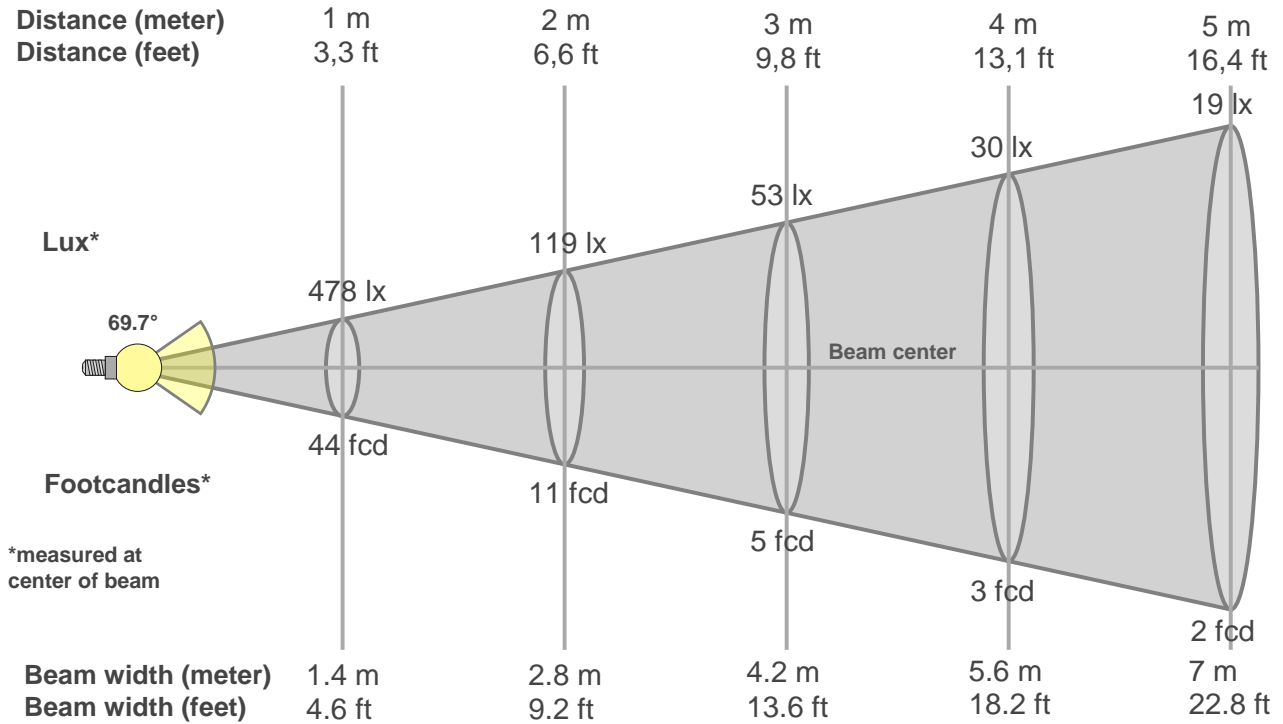

Beam intensities from 1-20m

1m	2m	3m	4m	5m	6m	7m	8m	9m	10m	11m	12m	13m	14m	15m	16m	17m	18m	19m	20m
3.3ft	6.6ft	9.8ft	13.1ft	16.4ft	19.7ft	23ft	26.2ft	29.5ft	32.8ft	36.1ft	39.4ft	42.7ft	45.9ft	49.2ft	52.5ft	55.8ft	59.1ft	62.3ft	65.6ft
478lx	119lx	53lx	30lx	19lx	13lx	10lx	7lx	6lx	5lx	4lx	3lx	3lx	2lx	2lx	2lx	2lx	1lx	1lx	1lx
44.4fcd	11.1fcd	4.9fcd	2.8fcd	1.8fcd	1.2fcd	0.9fcd	0.7fcd	0.5fcd	0.4fcd	0.4fcd	0.3fcd	0.3fcd	0.2fcd	0.2fcd	0.2fcd	0.2fcd	0.1fcd	0.1fcd	0.1fcd

Intensities in 0° c-plane

0°	5°	10°	15°	20°	25°	30°	35°	40°	45°	50°	55°	60°	65°	70°	75°	80°	85°	90°	95°
478	497	510	517	518	512	497	472	436	381	305	208	121	72	47	30	17	7	1	0
100%	104%	107%	108%	108%	107%	104%	99%	91%	80%	64%	43%	25%	15%	10%	6%	3%	1%	0%	0%

Intensities in 90° c-plane

0°	5°	10°	15°	20°	25°	30°	35°	40°	45°	50°	55°	60°	65°	70°	75°	80°	85°	90°	95°
478	487	478	460	432	390	334	272	211	158	116	85	65	50	35	22	11	4	1	0
100%	102%	100%	96%	90%	82%	70%	57%	44%	33%	24%	18%	14%	10%	7%	5%	2%	1%	0%	0%

Intensities in 180° c-plane

0°	5°	10°	15°	20°	25°	30°	35°	40°	45°	50°	55°	60°	65°	70°	75°	80°	85°	90°	95°
478	437	385	317	242	178	133	104	86	71	57	44	31	18	10	6	4	1	0	0
100%	91%	81%	66%	51%	37%	28%	22%	18%	15%	12%	9%	6%	4%	2%	1%	1%	0%	0%	0%

Intensities in 270° c-plane

0°	5°	10°	15°	20°	25°	30°	35°	40°	45°	50°	55°	60°	65°	70°	75°	80°	85°	90°	95°
478	475	453	419	370	310	247	188	140	103	78	60	45	31	18	8	3	1	0	0
100%	99%	95%	88%	78%	65%	52%	39%	29%	22%	16%	13%	9%	6%	4%	2%	1%	0%	0%	0%

Beam angle 50%	Field angle 10%	Cutoff angle 2,5%	Intensity ratio in 120° cone	Intensity ratio in 90° cone
69.7°	123.8°	151.1°	91.2%	71.4%

THIS PAGE INTENTIONALLY LEFT BLANK